



DVCL28 Series

HIGH RELIABILITY HYBRID INRUSH CURRENT LIMITER

DESCRIPTION

The DVCL28 Inrush Current Limiter is operable over the full military (-55 °C to +125 °C) temperature range with no power derating. The DVCL28 is designed to control the inrush current drawn by VPT's EMI filters and DC-DC converters during turn-on. The DVCL28 functions by limiting the rate of rise of its output voltage, and will also control the inrush current of discrete input capacitors.

The DVCL28 is designed and manufactured in a facility qualified to ISO9001 and certified to MIL-PRF-38534 Class H and K and MIL-STD-883.

This product may incorporate one or more of the following U.S. patents:

- 5,784,266
- 5,790,389
- 5,963,438
- 5,999,433
- 6,005,780
- 6,084,792
- 6,118,673

FEATURES

- High Reliability
- Small Size
- High Efficiency, Typically 99%
- Up to 200 Watts Output Power
- Wide Input Voltage Range: 11 to 50 Volts per MIL-STD-704
- High Input Transient Voltage: 80 Volts for 1 sec per MIL-STD-704A
- Undervoltage Lockout
- Inhibit Out
- Compatible with External Capacitance
- Precision Projection Welded Hermetic Package
- Additional Environmental Screening Available
- Meets MIL-STD-461 Revisions C, D, E and F EMC Requirements When Used With VPT DC-DC Converters and EMI filters
- MIL-PRF-38534 Element Evaluated Components



Figure 1 – DVCL28 Inrush Current Limiter
(Exact marking may differ from that shown)

SPECIFICATIONS ($T_{CASE} = -55^{\circ}\text{C}$ to $+125^{\circ}\text{C}$, $V_{IN} = +28\text{V} \pm 5\%$, Full Load, $C_{OUT} = 100\mu\text{F}$ Unless Otherwise Specified)

ABSOLUTE MAXIMUM RATINGS

Input Voltage (Continuous)	50 V _{DC}	Junction Temperature Rise to Case	+4°C
Input Voltage (Transient, 1 second)	80 Volts	Storage Temperature	-65°C to +150°C
Output Power ¹	200 Watts	Lead Solder Temperature (10 seconds)	270°C
Power Dissipation (Full Load, $T_{CASE} = +125^{\circ}\text{C}$)	8.5 Watts	Weight (Maximum)	16 Grams

Parameter	Conditions	DVCL28			Units	
		Min	Typ	Max		
STATIC						
INPUT Voltage	Continuous	11	28	50	V	
	Transient, 1 sec ²	-	-	80	V	
Inrush Current	Peak, $C_{OUT} = 100\mu\text{F}$	-	-	1.7	A _{PK}	
	Peak, $C_{OUT} = 500\mu\text{F}^2$	-	-	8.5	A _{PK}	
Current	No Load	-	10	14	mA	
UVLO Turn On		-	8.5	11	V	
OUTPUT Voltage		$V_{OUT} = V_{IN} - (I_{IN} \times R_{DC})$			V	
Current ^{1,3}		0	-	11	A	
Power ^{1,3}		0	-	200	W	
DC RESISTANCE	R _{DC}	-	30	70	mΩ	
POWER DISSIPATION		-	-	3.6	W	
CAPACITANCE	Pin to Case	2400	3300	4200	pF	
EXTERNAL CAPACITANCE		-	-	500	μF	
ISOLATION	Any Pin to Case, 500 V _{DC}	100	-	-	MΩ	
MTBF (MIL-HDBK-217F)	AIF @ $T_C = 55^{\circ}\text{C}$	-	445	-	kHrs	
DYNAMIC						
Turn On Delay	V _{OUT}	Vin=0V to 28V	-	6.2	11	mSec
Turn On Overshoot	V _{OUT}		-	-	50	mV _{PK}
Output Voltage Slope	V _{OUT}		-	6	13	V/ms

- Notes:
1. Derate linearly to 0 at 135°C.
 2. Verified by qualification testing.
 3. Rated current applies at any voltage.

PERFORMANCE CURVES

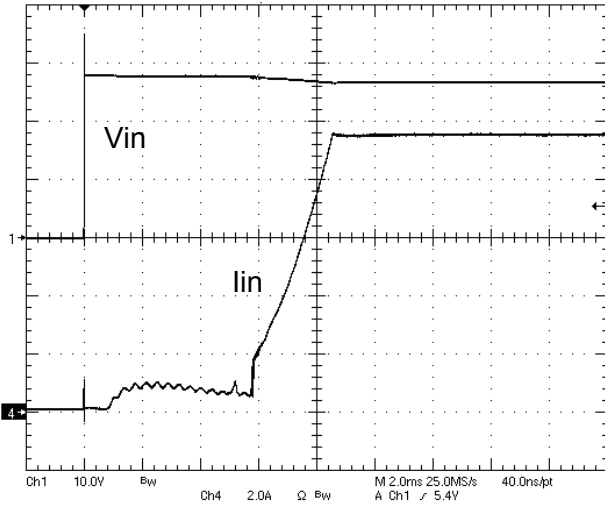

Figure 4 – Vin, lin during turn-on at 28V with DVME28, Cout=100µF and 2x DVFL2800S at full load

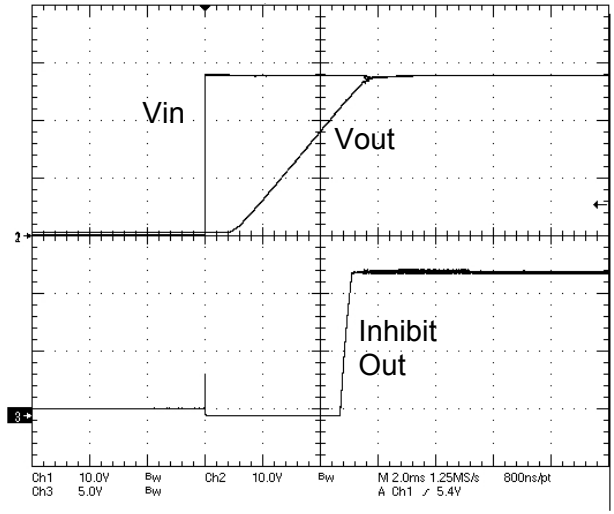

Figure 5 – Vin, Vout, Inhibit Out during turn-on at 28V

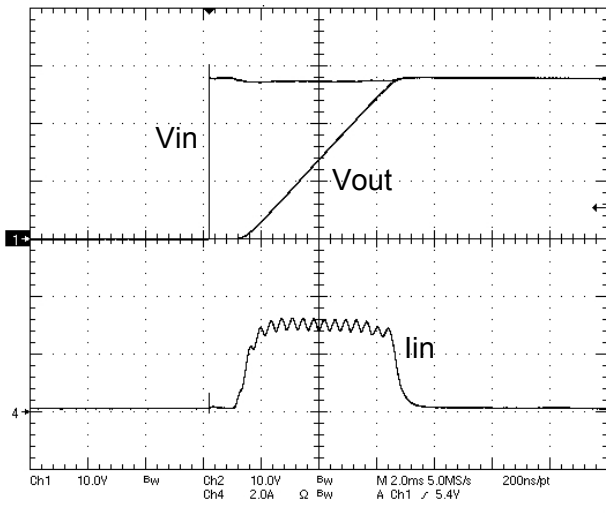

Figure 6 – Vin, Vout, lin during turn-on at 28V, Cout=500µF

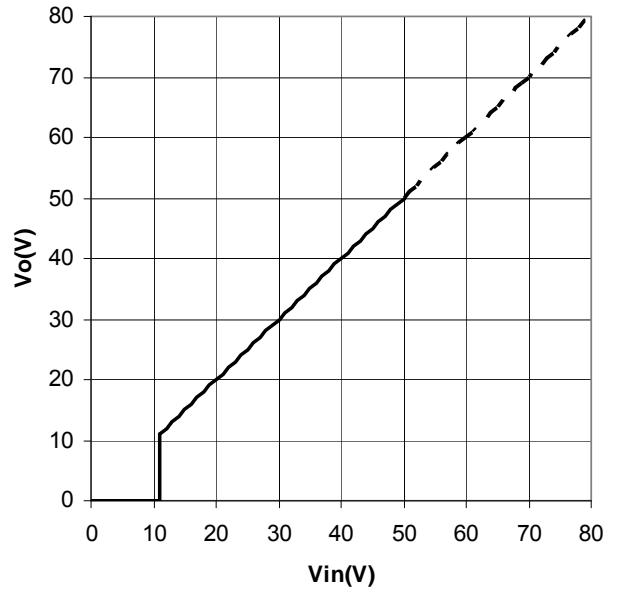
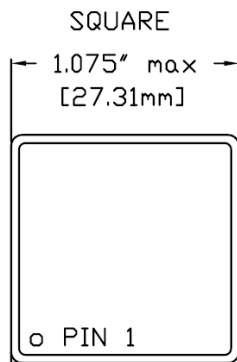
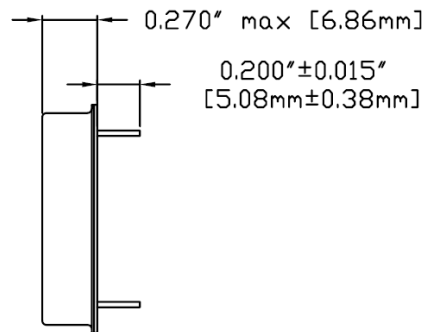

Figure 7 – Output Voltage vs. Input Voltage

PACKAGE SPECIFICATIONS



TOP VIEW



SIDE VIEW

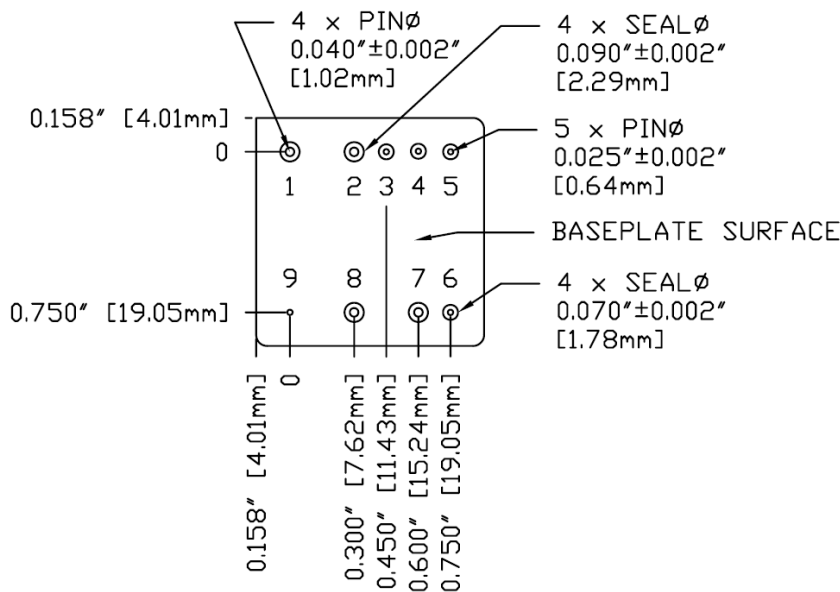

BOTTOM VIEW

NOTES:

1. DIMENSIONAL LIMITS ARE $\pm 0.005"$ UNLESS OTHERWISE STATED.
2. CASE TEMPERATURE IS MEASURED ON THE CENTER OF THE BASEPLATE.
3. MATERIALS:
CASE: STEEL, GOLD OVER NICKEL PLATED.
COVER: STEEL, NICKEL PLATED.
PINS: COPPER CORED ALLOY 52 ($0.040"$ Ø), ALLOY 52 ($0.025"$ Ø), GOLD OVER NICKEL PLATED.
PIN SEALS: GLASS

PIN	FUNCTION	PIN	FUNCTION	PIN	FUNCTION
1	+VIN	4	NC	7	COM
2	COM	5	NC	8	+VOUT
3	NC	6	INH OUT	9	CASE

Figure 8 – Package and Pinout
 (Note: NC pins can be connected to COM)

PACKAGE PIN DESCRIPTION

Pin	Function	Description
1	+VIN	Positive Input Voltage Connection
2	COM	Common Return Connection, Input Side
3	NC	No Connection. Leave Open or Connect to COM.
4	NC	No Connection. Leave Open or Connect to COM.
5	NC	No Connection. Leave Open or Connect to COM.
6	INH OUT	Inhibit Out. Open Collector Output. Connects to Load Converter INH Input.
7	COM	Common Return Connection, Output Side
8	+VOUT	Positive Output Voltage Connection
9	CASE	Case Connection

ENVIRONMENTAL SCREENING (100% Tested Per MIL-STD-883 as referenced to MIL-PRF-38534 where required)

Screening	MIL-STD-883	Standard (No Suffix)	Extended /ES	HB /HB	Class H /H	Class K /K
Non-Destructive Bond Pull	Method 2023	•	•	•	•	•
Internal Visual	Method 2017, 2032 Internal Procedure	•	•	•	•	•
Temperature Cycling	Method 1010, Condition C Method 1010, -55°C to 125°C		•	•	•	•
Constant Acceleration	Method 2001, 3000g, Y1 Direction Method 2001, 500g, Y1 Direction		•	•	•	•
PIND	Method 2020, Condition A ²					•
Pre Burn-In Electrical	100% at 25°C					•
Burn-In	Method 1015, 320 hours at +125°C Method 1015, 160 hours at +125°C 96 hours at +125°C 24 hours at +125°C	•	•	•	•	•
Final Electrical	MIL-PRF-38534, Group A ¹ 100% at 25°C	•	•	•	•	•
Hermeticity	Method 1014, Fine Leak, Condition A Method 1014, Gross Leak, Condition C Dip (1 x 10 ⁻³)	•	•	•	•	•
Radiography	Method 2012 ³					•
External Visual	Method 2009	•	•	•	•	•

- Notes:
- 100% R&R testing at -55°C, +25°C, and +125°C with all test data included in product shipment.
 - PIND test Certificate of Compliance included in product shipment.
 - Radiographic test Certificate of Compliance and film(s) included in product shipment.

ORDERING INFORMATION

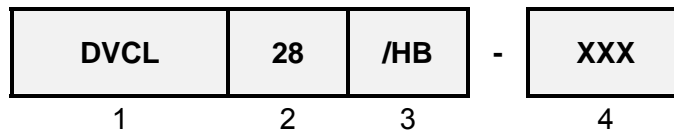

(1)	(2)		(3)		(4)
Product Series	Nominal Input Voltage		Screening Code ^{1,2}		Additional Screening Code
DVCL	28	28 Volts	None /ES /HB /H /K	Standard Extended HB Class H Class K	Contact Sales

- Notes:
1. Contact the VPT Inc. Sales Department for availability of Class H (/H) or Class K (/K) qualified products.
 2. VPT Inc. reserves the right to ship higher screened or DSCC Drawing products to meet lower screened orders at our sole discretion unless specifically forbidden by customer contract.

Please contact your sales representative or the VPT Inc. Sales Department for more information concerning additional environmental screening and testing, different input voltage, output voltage, power requirement, source inspection, and/or special element evaluation for space or other higher quality applications.

SMD (STANDARD MICROCIRCUIT DRAWING) NUMBERS

Standard Microcircuit Drawing (SMD)	DVCL Series Similar Part Number
*T.B.D.	DVCL28/H

Do not use the DVCL28 Series similar part number for SMD product acquisition. It is listed for reference only. For exact specifications for the SMD product, refer to the SMD drawing. SMD's can be downloaded from the DLA Land and Maritime (Previously known as DSCC) website at <http://www.dsccl.dla.mil/programs/smcr/>. The SMD number listed above is for MIL-PRF-38534 Class H screening, standard gold plated lead finish, and no RHA (Radiation Hardness Assurance) level. Please reference the SMD for other screening levels, lead finishes, and radiation levels. All SMD products are marked with a "Q" on the cover as specified by the QML certification mark requirement of MIL-PRF-38534.

CONTACT INFORMATION

To request a quotation or place orders please contact your sales representative or the VPT Inc. Sales Department at:

Phone: (425) 353-3010
Fax: (425) 353-4030
E-mail: vptsales@vpt-inc.com

All information contained in this datasheet is believed to be accurate, however, no responsibility is assumed for possible errors or omissions. The products or specifications contained herein are subject to change without notice.