



DVETR2800S Series

HIGH RELIABILITY HYBRID DC-DC CONVERTERS WITH INTEGRAL EMI FILTER

DESCRIPTION

The DVETR series of high reliability DC-DC converters is operable over the full military (-55 °C to +125 °C) temperature range with no power derating. Unique to the DVETR series are robust and effective input and output filters which provide dramatically reduced input and output noise performance when compared to other manufacturers competing devices. Operating at a nominal fixed frequency of 500 kHz, these regulated, isolated units utilize a high speed magnetic feedback design and well controlled undervoltage lockout circuitry to eliminate slow start-up problems.

These converters are designed and manufactured in a facility qualified to ISO9001 and certified to MIL-PRF-38534 and MIL-STD-883.

This product may incorporate one or more of the following U.S. patents:

5,784,266
5,790,389
5,963,438
5,999,433
6,005,780
6,084,792
6,118,673

FEATURES

- High Reliability
- Very Low Output Noise
- Wide Input Voltage Range: 15 to 50 Volts per MIL-STD-704
- Up to 40 Watts Output Power
- Fault Tolerant Magnetic Feedback Circuit
- NO Use of Optoisolators
- Undervoltage Lockout
- Indefinite Short Circuit Protection
- Current Limit Protection
- Industry Standard Pinout
- High Input Transient Voltage: 80 Volts for 1 sec per MIL-STD-704A
- Precision Seam Welded Hermetic Package
- High Power Density: > 30 W/in³
- Custom Versions Available
- Additional Environmental Screening Available
- No External EMI Filter Required
- Meets MIL-STD-461 Revisions C, D, E and F EMC Requirements When Used With VPT's EMI Filters
- Protects Against Conducted Susceptibility Specified in MIL-STD-461C, CS01 and CS02
- Flanged and Non-flanged Versions Available
- MIL-PRF-38534 Element Evaluated Components

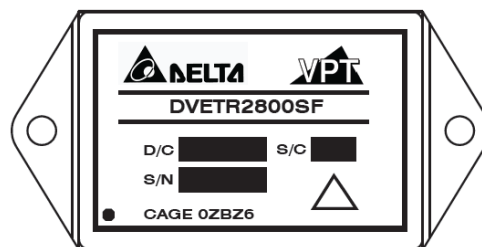

Figure 1 – DVETR2800S / DVETR2800SF DC-DC Converter
(Exact marking may differ from that shown)

SPECIFICATIONS ($T_{CASE} = -55^{\circ}\text{C}$ to $+125^{\circ}\text{C}$, $V_{IN} = +28\text{V} \pm 5\%$, Full Load, Unless Otherwise Specified)

ABSOLUTE MAXIMUM RATINGS

Input Voltage (Continuous)	50 V_{DC}	Junction Temperature Rise to Case	+15°C
Input Voltage (Transient, 1 second)	80 Volts	Storage Temperature	-65°C to +150°C
Output Power ¹	40 Watts	Lead Solder Temperature (10 seconds)	270°C
Power Dissipation (Full Load, $T_{CASE} = +125^{\circ}\text{C}$)	14 Watts	Weight (Maximum) (Un-Flanged / Flanged)	(56 / 60) Grams

Parameter	Conditions	DVETR283R3S			DVETR2805S			Units
		Min	Typ	Max	Min	Typ	Max	
STATIC								
INPUT Voltage ⁴	Continuous	15	28	50	15	28	50	V
	Transient, 1 sec	-	-	80	-	-	80	V
Current	Inhibited	-	-	6	-	-	6	mA
	No Load	-	-	90	-	-	90	mA
Inhibit Pin Input ⁴		0	-	1.5	0	-	1.5	V
Inhibit Pin Open Circuit Voltage ⁴		9.0	11.0	13.0	9.0	11.0	13.0	V
UVLO Turn On		12.0	-	14.8	12.0	-	14.8	V
UVLO Turn Off ⁴		11.0	-	14.5	11.0	-	14.5	V
OUTPUT Voltage	V_{OUT} $T_{CASE} = 25^{\circ}\text{C}$	3.267	3.30	3.333	4.95	5.00	5.05	V
	V_{OUT} $T_{CASE} = -55^{\circ}\text{C}$ to $+125^{\circ}\text{C}$	3.25	3.30	3.35	4.90	5.00	5.10	V
Power ³		0	-	20	0	-	30	W
Current ³	V_{OUT}	0	-	6.06	0	-	6.0	A
Ripple Voltage	V_{OUT} Full Load, 20Hz to 10MHz	-	-	50	-	-	50	mV _{pp}
Line Regulation	V_{OUT} $V_{IN} = 15\text{V}$ to 50V	-	-	20	-	-	20	mV
Load Regulation	V_{OUT} No Load to Full Load	-	-	50	-	-	50	mV
EFFICIENCY		65	-	-	70	-	-	%
LOAD FAULT POWER DISSIPATION	Overload ⁴	-	-	16	-	-	16	W
	Short Circuit	-	-	16	-	-	16	W
CAPACITIVE LOAD ⁴		-	-	1000	-	-	1000	μF
SWITCHING FREQUENCY		400	475	550	450	500	550	kHz
ISOLATION	500 V_{DC}	100	-	-	100	-	-	M Ω
MTBF (MIL-HDBK-217F)	AIF @ $T_C = 55^{\circ}\text{C}$	-	413	-	-	413	-	kHrs
DYNAMIC								
Load Step Output Transient	V_{OUT} Half Load to Full Load	-	-	400	-	-	500	mV _{PK}
Load Step Recovery ²		-	-	500	-	-	500	μSec
Line Step Output Transient ⁴	V_{OUT} $V_{IN} = 16\text{V}$ to 40V	-	150	600	-	150	600	mV _{PK}
Line Step Recovery ^{2,4}		-	100	500	-	100	500	μSec
Turn On Delay	V_{OUT} $V_{IN} = 0\text{V}$ to 28V	-	-	20	-	-	20	mSec
Turn On Overshoot		-	-	30	-	-	50	mV _{PK}

Notes: 1. Dependant on output voltage. 2. Time for output voltage to settle within 1% of its nominal value.
3. Derate linearly to 0 at 135°C. 4. Verified by qualification testing.

SPECIFICATIONS ($T_{CASE} = -55^{\circ}\text{C}$ to $+125^{\circ}\text{C}$, $V_{IN} = +28\text{V} \pm 5\%$, Full Load, Unless Otherwise Specified)

ABSOLUTE MAXIMUM RATINGS

Input Voltage (Continuous)	50 V_{DC}	Junction Temperature Rise to Case	+15°C
Input Voltage (Transient, 1 second)	80 Volts	Storage Temperature	-65°C to +150°C
Output Power ¹	40 Watts	Lead Solder Temperature (10 seconds)	270°C
Power Dissipation (Full Load, $T_{CASE} = +125^{\circ}\text{C}$)	14 Watts	Weight (Maximum) (Un-Flanged / Flanged)	(56 / 60) Grams

Parameter	Conditions	DVETR2812S			DVETR2815S			Units
		Min	Typ	Max	Min	Typ	Max	
STATIC								
INPUT Voltage ⁴	Continuous	15	28	50	15	28	50	V
	Transient, 1 sec	-	-	80	-	-	80	V
Current	Inhibited	-	-	6	-	-	6	mA
	No Load	-	-	90	-	-	90	mA
Inhibit Pin Input ⁴		0	-	1.5	0	-	1.5	V
Inhibit Pin Open Circuit Voltage ⁴		9.0	11.0	13.0	9.0	11.0	13.0	V
UVLO Turn On		12.0	-	14.8	12.0	-	14.8	V
UVLO Turn Off ⁴		11.0	-	14.5	11.0	-	14.5	V
OUTPUT Voltage	V_{OUT} $T_{CASE} = 25^{\circ}\text{C}$	11.88	12.0	12.12	14.85	15.0	15.15	V
	V_{OUT} $T_{CASE} = -55^{\circ}\text{C}$ to $+125^{\circ}\text{C}$	11.72	12.0	12.18	14.775	15.0	15.225	V
Power ³		0	-	40	0	-	40	W
Current ³	V_{OUT}	0	-	3.33	0	-	2.67	A
Ripple Voltage	V_{OUT} Full Load, 20Hz to 10MHz	-	-	50	-	-	50	mV _{pp}
Line Regulation	V_{OUT} $V_{IN} = 15\text{V}$ to 50V	-	-	20	-	-	20	mV
Load Regulation	V_{OUT} No Load to Full Load	-	-	50	-	-	50	mV
EFFICIENCY		74	-	-	75	-	-	%
LOAD FAULT POWER DISSIPATION	Overload ⁴	-	-	16	-	-	16	W
	Short Circuit	-	-	16	-	-	16	W
CAPACITIVE LOAD ⁴		-	-	500	-	-	500	μF
SWITCHING FREQUENCY		400	475	550	400	475	550	kHz
ISOLATION	500 V_{DC}	100	-	-	100	-	-	M Ω
MTBF (MIL-HDBK-217F)	AIF @ $T_C = 55^{\circ}\text{C}$	-	413	-	-	413	-	kHrs
DYNAMIC								
Load Step Output Transient	V_{OUT} Half Load to Full Load	-	-	700	-	-	800	mV _{PK}
Load Step Recovery ²		-	-	500	-	-	500	μSec
Line Step Output Transient ⁴	V_{OUT} $V_{IN} = 16\text{V}$ to 40V	-	800	1200	-	800	1200	mV _{PK}
Line Step Recovery ^{2,4}		-	300	500	-	300	500	μSec
Turn On Delay	V_{OUT} $V_{IN} = 0\text{V}$ to 28V	-	-	20	-	-	20	mSec
Turn On Overshoot		-	-	50	-	-	50	mV _{PK}

Notes: 1. Dependant on output voltage. 2. Time for output voltage to settle within 1% of its nominal value.
3. Derate linearly to 0 at 135°C. 4. Verified by qualification testing.

SPECIFICATIONS ($T_{CASE} = -55^{\circ}\text{C}$ to $+125^{\circ}\text{C}$, $V_{IN} = +28\text{V} \pm 5\%$, Full Load, Unless Otherwise Specified)

ABSOLUTE MAXIMUM RATINGS

Input Voltage (Continuous)	50 V_{DC}	Junction Temperature Rise to Case	+15°C
Input Voltage (Transient, 1 second)	80 Volts	Storage Temperature	-65°C to +150°C
Output Power ¹	40 Watts	Lead Solder Temperature (10 seconds)	270°C
Power Dissipation (Full Load, $T_{CASE} = +125^{\circ}\text{C}$)	14 Watts	Weight (Maximum) (Un-Flanged / Flanged)	(56 / 60) Grams

Parameter	Conditions	DVETR285R2S			DVETR285R7S			Units
		Min	Typ	Max	Min	Typ	Max	
STATIC								
INPUT Voltage ⁴	Continuous	15	28	50	15	28	50	V
	Transient, 1 sec	-	-	80	-	-	80	V
Current	Inhibited	-	-	6	-	-	6	mA
	No Load	-	-	90	-	-	90	mA
Inhibit Pin Input ⁴		0	-	1.5	0	-	1.5	V
Inhibit Pin Open Circuit Voltage ⁴		9.0	11.0	13.0	9.0	11.0	13.0	V
UVLO Turn On		12.0	-	14.8	12.0	-	14.8	V
UVLO Turn Off ⁴		11.0	-	14.5	11.0	-	14.5	V
OUTPUT Voltage	V_{OUT} $T_{CASE} = 25^{\circ}\text{C}$	5.14	5.20	5.26	5.64	5.70	5.76	V
	V_{OUT} $T_{CASE} = -55^{\circ}\text{C}$ to $+125^{\circ}\text{C}$	5.09	5.20	5.31	5.58	5.70	5.82	V
Power ³		0	-	30	0	-	30	W
Current ³	V_{OUT}	0	-	5.8	-	-	5.3	A
Ripple Voltage	V_{OUT} Full Load, 20Hz to 10MHz	-	-	50	-	-	50	mV _{pp}
Line Regulation	V_{OUT} $V_{IN} = 15\text{V}$ to 50V	-	-	20	-	-	20	mV
Load Regulation	V_{OUT} No Load to Full Load	-	-	50	-	-	50	mV
EFFICIENCY		70	-	-	70	77	-	%
LOAD FAULT POWER DISSIPATION	Overload ⁴	-	-	16	-	-	16	W
	Short Circuit	-	-	16	-	-	16	W
CAPACITIVE LOAD ⁴		-	-	1000	-	-	1000	μF
SWITCHING FREQUENCY		400	500	550	400	500	550	kHz
ISOLATION	500 V_{DC}	100	-	-	100	-	-	M Ω
MTBF (MIL-HDBK-217F)	AIF @ $T_C = 55^{\circ}\text{C}$	-	413	-	-	413	-	kHrs
DYNAMIC								
Load Step Output Transient	V_{OUT} Half Load to Full Load	-	-	500	-	-	500	mV _{PK}
Load Step Recovery ²		-	-	500	-	-	500	μSec
Line Step Output Transient ⁴	V_{OUT} $V_{IN} = 16\text{V}$ to 40V	-	150	600	-	-	600	mV _{PK}
Line Step Recovery ^{2,4}		-	100	500	-	-	500	μSec
Turn On Delay	V_{OUT} $V_{IN} = 0\text{V}$ to 28V	-	-	20	-	-	20	mSec
Turn On Overshoot		-	-	50	-	-	50	mV _{PK}

Notes: 1. Dependant on output voltage. 2. Time for output voltage to settle within 1% of its nominal value.
3. Derate linearly to 0 at 135°C. 4. Verified by qualification testing.

BLOCK DIAGRAM

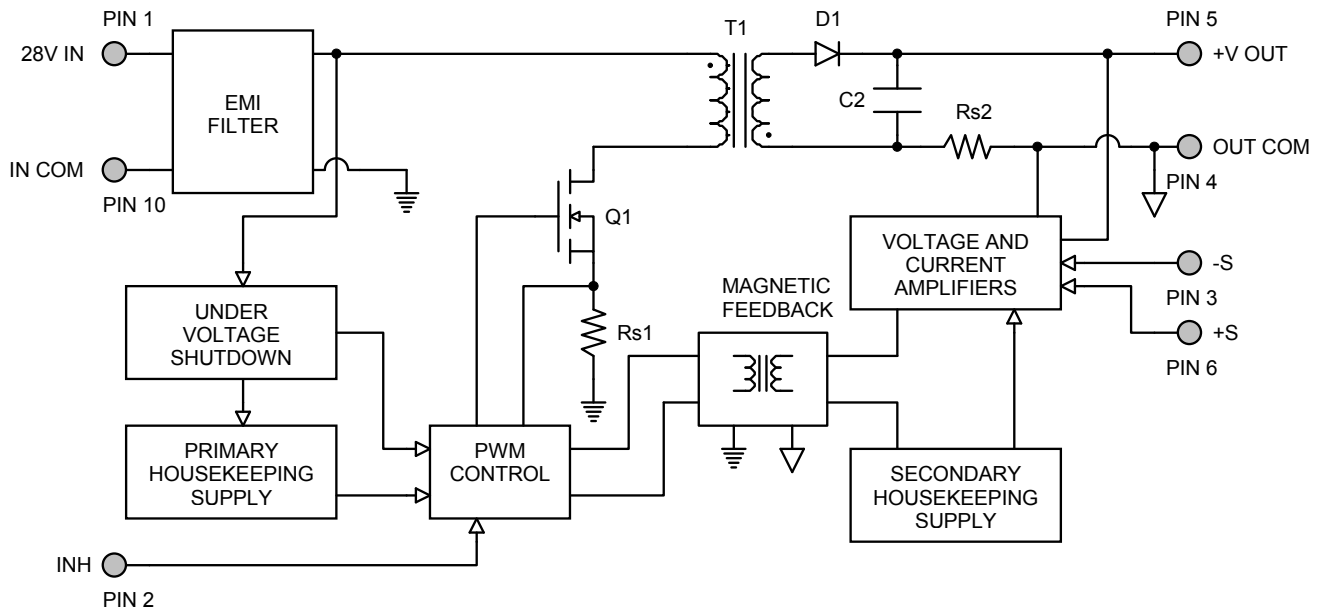

Figure 2

CONNECTION DIAGRAM

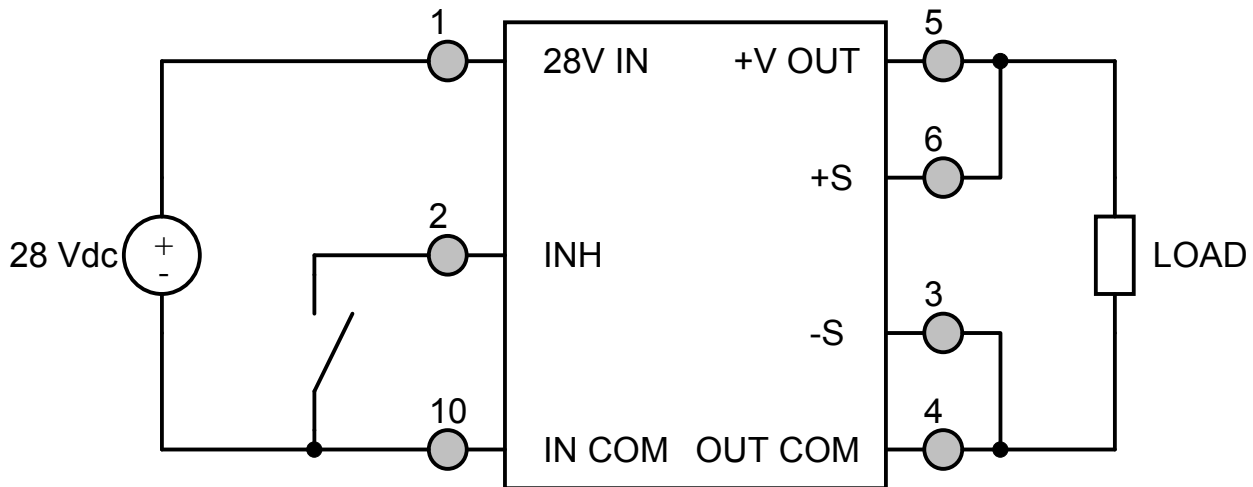

Figure 3

INHIBIT DRIVE CONNECTION DIAGRAMS

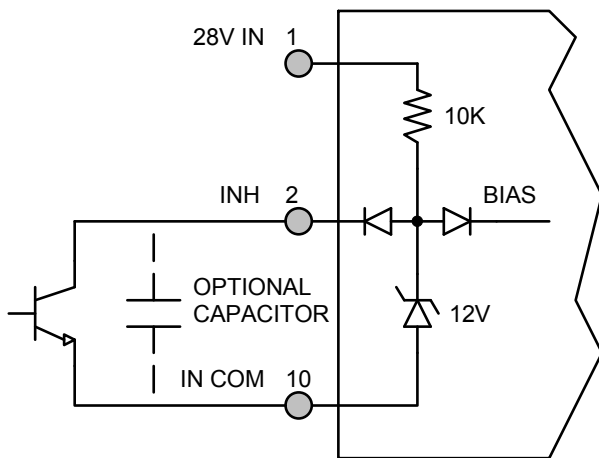

Figure 4 – Internal Inhibit Circuit and Recommended Drive
(Shown with optional capacitor for turn-on delay)

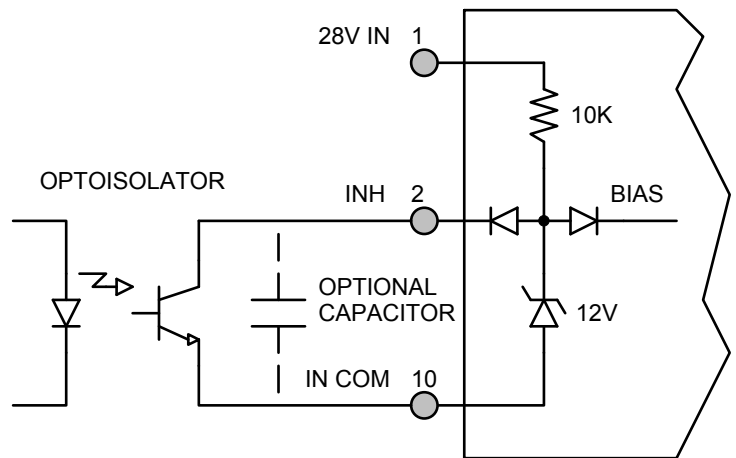
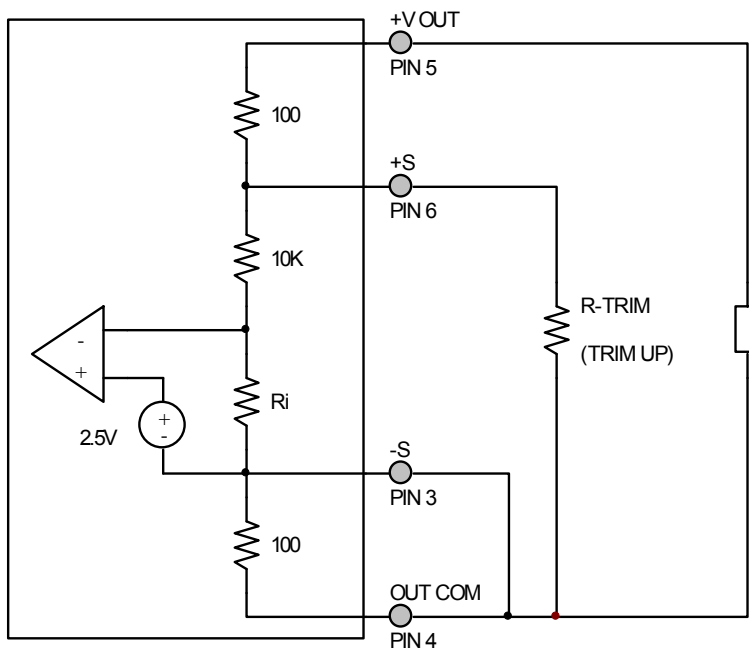

Figure 5 – Isolated Inhibit Drive
(Shown with optional capacitor for turn-on delay)

OUTPUT VOLTAGE TRIM



The output voltage can be trimmed up by connecting a resistor between the +S pin (PIN 6) and the OUT COM pin (PIN 4). The maximum trim range is +10%. The appropriate resistor values versus the output voltage are given in the trim table below. The -S pin should be connected to the OUT COM pin.

Figure 6 – Output Voltage Trim

DVETR283R3S		DVETR2805S		DVETR285R2S		DVETR285R7S		DVETR2812S		DVETR2815S	
+V _{OUT} (V)	R _{TRIM} (Ω)	+V _{OUT} (V)	R _{TRIM} (Ω)	+V _{OUT} (V)	R _{TRIM} (Ω)	+V _{OUT} (V)	R _{TRIM} (Ω)	+V _{OUT} (V)	R _{TRIM} (Ω)	+V _{OUT} (V)	R _{TRIM} (Ω)
3.60	1.13k	5.50	1.05k	5.70	1.09k	6.25	1.1k	13.2	1.09k	16.50	1.09k
3.55	1.36k	5.45	1.18k	5.65	1.22k	6.20	1.22k	13.1	1.19k	16.40	1.18k
3.50	1.72k	5.40	1.33k	5.60	1.39k	6.15	1.36k	13.0	1.33k	16.30	1.28k
3.45	2.32k	5.35	1.54k	5.55	1.60k	6.10	1.55k	12.9	1.49k	16.20	1.4k
3.40	3.59k	5.30	1.82k	5.50	1.89k	6.05	1.79k	12.8	1.7k	16.10	1.54k
3.35	7.87k	5.25	2.22k	5.45	2.31k	6.00	2.13k	12.7	1.98k	16.00	1.71k
3.30	-	5.20	2.86k	5.40	2.97k	5.95	2.62k	12.6	2.38k	15.90	1.94k
		5.15	4k	5.35	4.16k	5.90	3.39k	12.5	2.96k	15.80	2.22k
		5.10	6.67k	5.30	6.93k	5.85	4.83k	12.4	3.94k	15.70	2.61k
		5.05	20k	5.25	20.8k	5.80	8.38k	12.3	5.86k	15.60	3.16k
		5.00	-	5.20	-	5.75	31.7k	12.2	11.4k	15.50	4k
						5.70	-	12.1	242k	15.40	5.46k
								12.0	-	15.30	8.57k
										15.20	20k
										15.10	Note 1
										15.00	-

Notes: 1. Connect R-TRIM = 400Ω from +VOUT (PIN 5) to +S (PIN 6).

EFFICIENCY PERFORMANCE CURVES ($T_{CASE} = 25^{\circ}C$, Full Load, Unless Otherwise Specified)

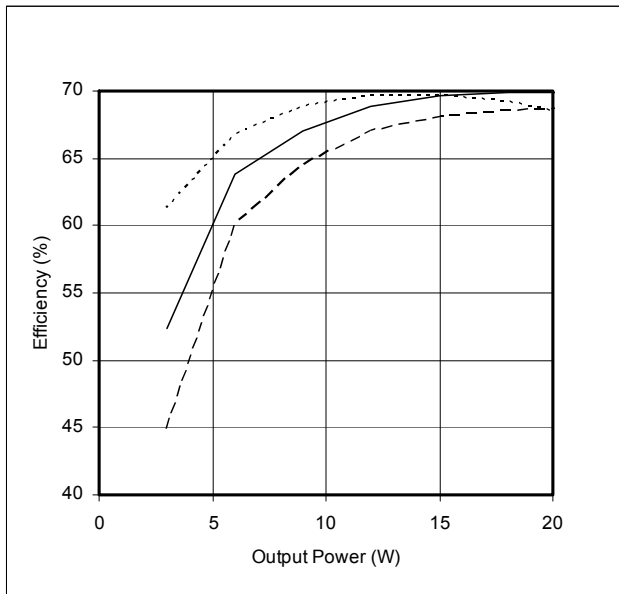
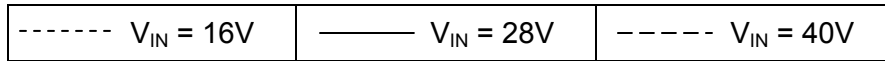

Figure 7 – DVETR283R3S
Efficiency (%) vs. Output Power (W)

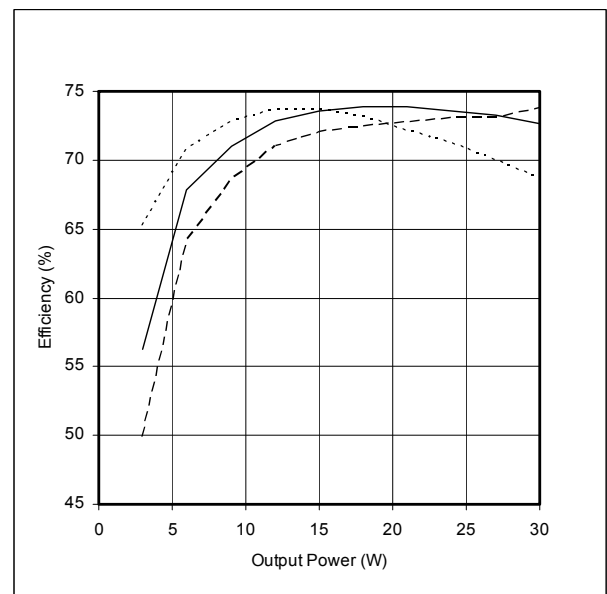

Figure 8 – DVETR2805S / DVETR285R2S
Efficiency (%) vs. Output Power (W)

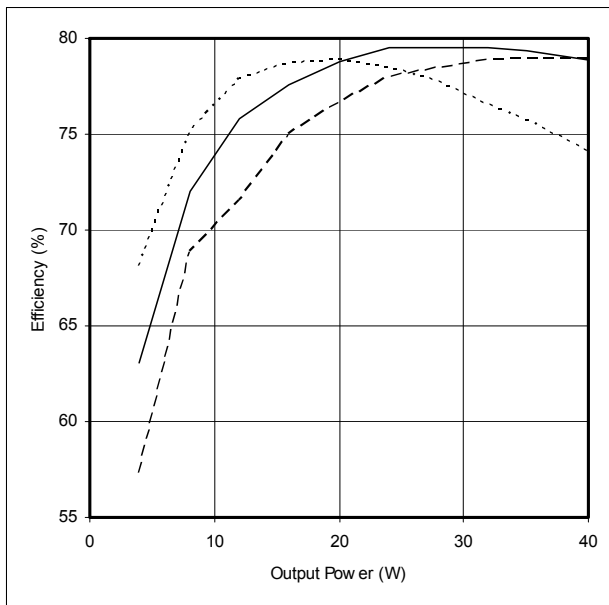

Figure 9 – DVETR2812S
Efficiency (%) vs. Output Power (W)

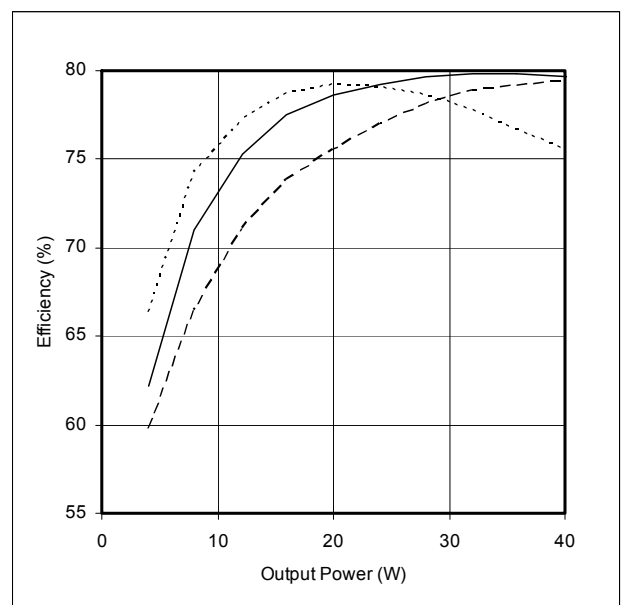

Figure 10 – DVETR2815S
Efficiency (%) vs. Output Power (W)

EMI PERFORMANCE CURVES

($T_{CASE} = 25^{\circ}C$, $V_{IN} = +28V \pm 5\%$, Full Load, Unless Otherwise Specified)

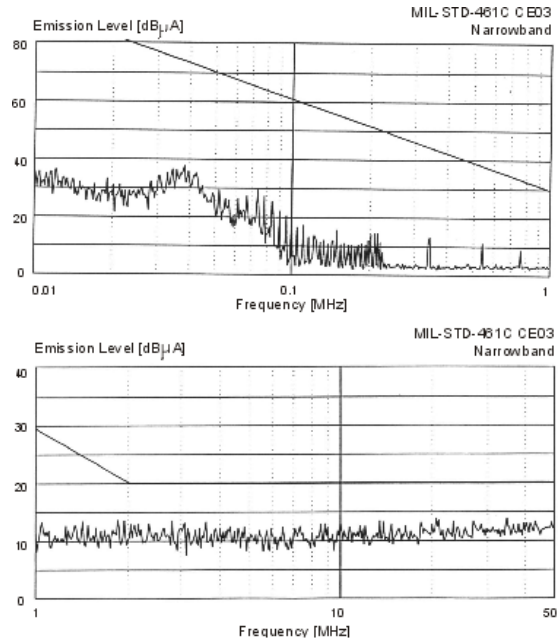

Figure 11 – MIL-STD-461C
DVETR2800S

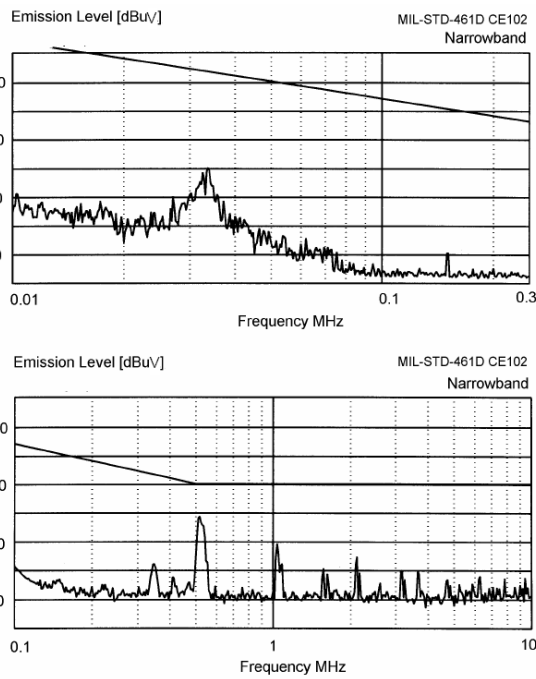
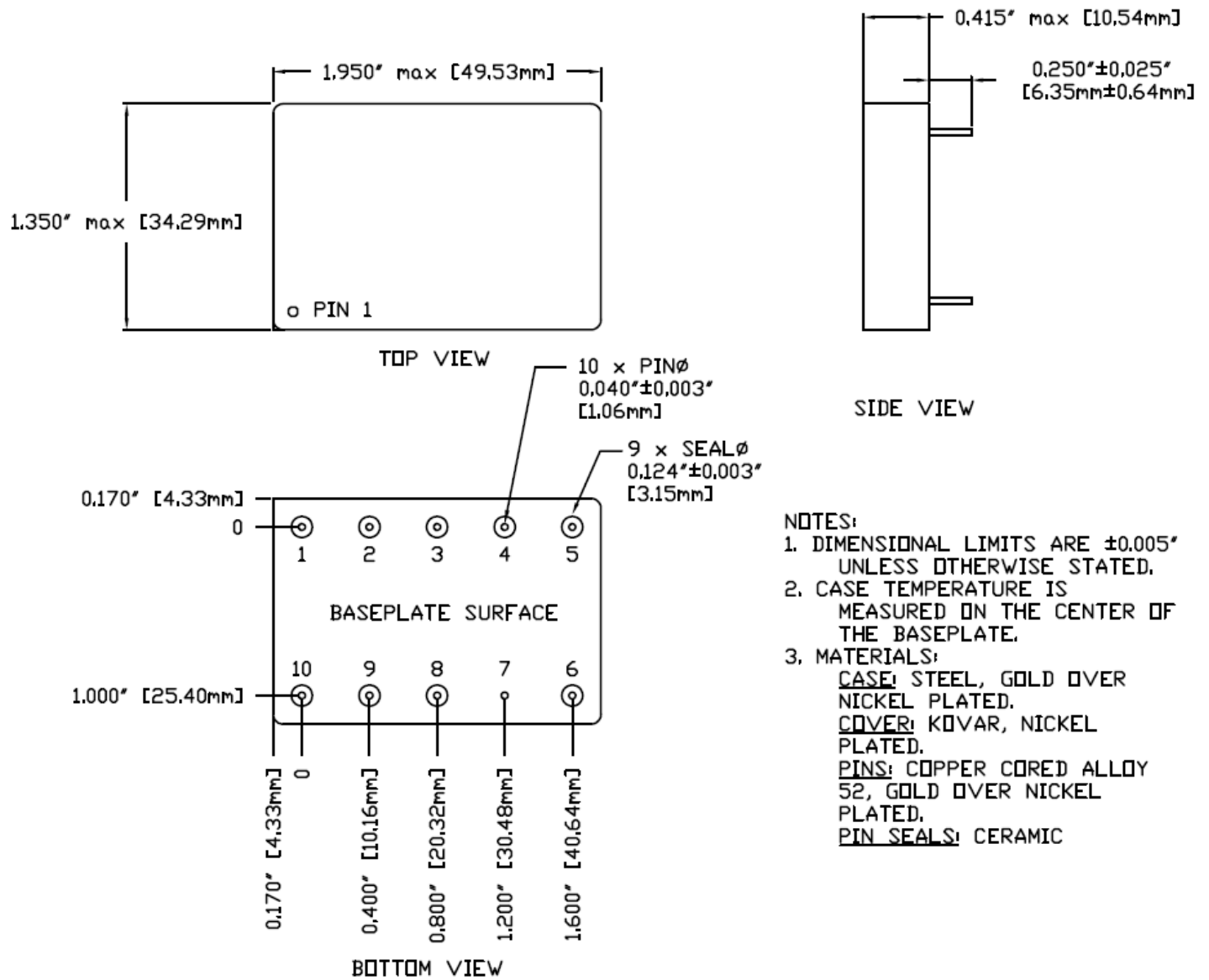

Figure 12 – MIL-STD-461D
DVETR2800S

PACKAGE SPECIFICATIONS (NON-FLANGED, SEAM SEAL)



PIN	FUNCTION	PIN	FUNCTION
1	28V IN	6	+S
2	INHIBIT	7	CASE
3	-S	8	N/C
4	OUT COM	9	N/C
5	+V OUT	10	IN COM

Figure 13 – Non-Flanged, Seam Seal Package and Pinout

PACKAGE SPECIFICATIONS (FLANGED, SEAM SEAL)

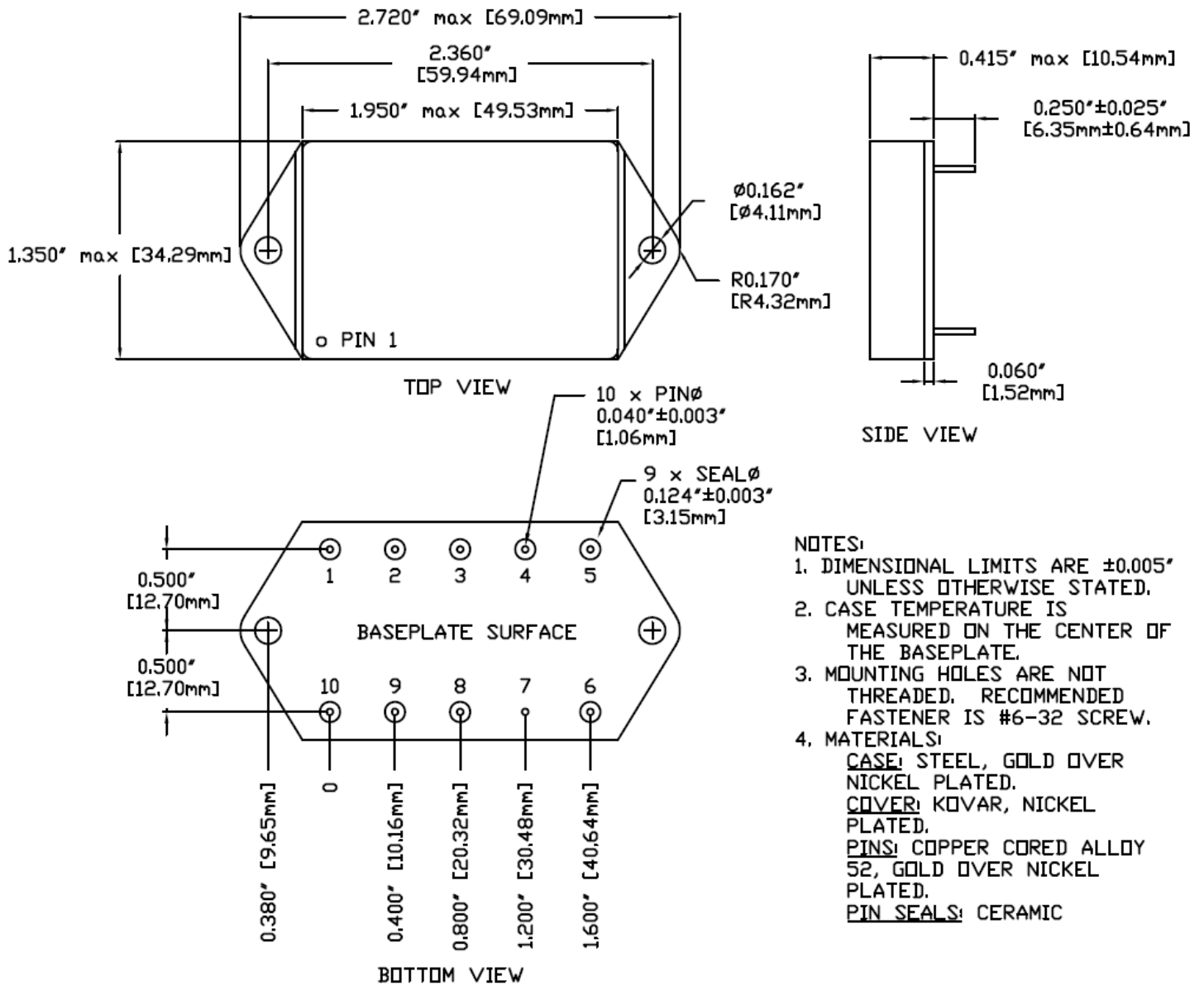

PIN	FUNCTION	PIN	FUNCTION
1	28V IN	6	+S
2	INHIBIT	7	CASE
3	-S	8	N/C
4	OUT COM	9	N/C
5	+V OUT	10	IN COM

Figure 14 – Flanged, Seam Seal Package and Pinout

PACKAGE PIN DESCRIPTION

Pin	Function	Description
1	28V IN	Positive Input Voltage Connection
2	INHIBIT	Logic Low = Disabled Output. Connecting the inhibit pin to input common causes converter shutdown. Logic High = Enabled Output. Unconnected or open collector TTL.
3	-S	Return Sense
4	OUT COM	Output Common Connection
5	+V OUT	Positive Output Voltage Connection
6	+S	Positive Sense
7	CASE	Case Connection
8	N/C	No Connection
9	N/C	No Connection
10	IN COM	Input Common Connection

ENVIRONMENTAL SCREENING (100% Tested Per MIL-STD-883 as referenced to MIL-PRF-38534)

Screening	MIL-STD-883	Standard (No Suffix)	Extended /ES	HB /HB	Class H /H	Class K /K
Non-Destructive Bond Pull	Method 2023	•	•	•	•	•
Internal Visual	Method 2017, 2032 Internal Procedure	•	•	•	•	•
Temperature Cycling	Method 1010, Condition C Method 1010, -55°C to 125°C		•	•	•	•
Constant Acceleration	Method 2001, 3000g, Y1 Direction Method 2001, 500g, Y1 Direction		•	•	•	•
PIND	Method 2020, Condition A ²					•
Pre Burn-In Electrical	100% at 25°C					•
Burn-In	Method 1015, 320 hours at +125°C Method 1015, 160 hours at +125°C 96 hours at +125°C 24 hours at +125°C	•	•	•	•	•
Final Electrical	MIL-PRF-38534, Group A ¹ 100% at 25°C	•	•	•	•	•
Hermeticity	Method 1014, Fine Leak, Condition A Method 1014, Gross Leak, Condition C Dip (1 x 10 ⁻³)	•	•	•	•	•
Radiography	Method 2012 ³					•
External Visual	Method 2009	•	•	•	•	•

- Notes:
1. 100% R&R testing at -55°C, +25°C, and +125°C with all test data included in product shipment.
 2. PIND test Certificate of Compliance included in product shipment.
 3. Radiographic test Certificate of Compliance and film(s) included in product shipment.

ORDERING INFORMATION

DVETR	28	05	S	F	/HB	-	XXX
1	2	3	4	5	6		7

(1) Product Series	(2) Nominal Input Voltage		(3) Output Voltage		(4) Number of Outputs	
DVETR	28	28 Volts	3R3 05 5R2 5R7 12 15	3.3 Volts 5 Volts 5.2 Volts 5.7 Volts 12 Volts 15 Volts	S	Single

(5) Package Option		(6) Screening Code ¹		(7) Additional Screening Code
None F	Non-Flanged Flanged	None /ES /HB /H /K	Standard Extended HB Class H Class K	Contact Sales

- Notes:
1. Contact the VPT Inc. Sales Department for availability of Class H (/H) or Class K (/K) qualified products.
 2. VPT Inc. reserves the right to ship higher screened or SMD products to meet lower screened orders at our sole discretion unless specifically forbidden by customer contract.

Please contact your sales representative or the VPT Inc. Sales Department for more information concerning additional environmental screening and testing, different input voltage, output voltage, power requirement, source inspection, and/or special element evaluation for space or other higher quality applications.

SMD (STANDARD MICROCIRCUIT DRAWING) NUMBERS

Standard Microcircuit Drawing (SMD)	DVETR2800S Series Similar Part Number
*T.B.D.	DVETR283R3S/H DVETR283R3SF/H
*T.B.D.	DVETR2805S/H DVETR2805SF/H
*T.B.D.	DVETR285R2S/H DVETR285R2SF/H
*T.B.D.	DVETR285R7S/H DVETR285R7SF/H
*T.B.D.	DVETR2812S/H DVETR2812SF/H
*T.B.D.	DVETR2815S/H DVETR2815SF/H

Do not use the DVETR2800S Series similar part number for SMD product acquisition. It is listed for reference only. For exact specifications for the SMD product, refer to the SMD drawing. SMD's can be downloaded from the DLA Land and Maritime (Previously known as DSCC) website at <http://www.dsccl.dla.mil/programs/smcr/>. The SMD number listed above is for MIL-PRF-38534 Class H screening, standard gold plated lead finish, and no RHA (Radiation Hardness Assurance) level. Please reference the SMD for other screening levels, lead finishes, and radiation levels. All SMD products are marked with a "Q" on the cover as specified by the QML certification mark requirement of MIL-PRF-38534.

CONTACT INFORMATION

To request a quotation or place orders please contact your sales representative or the VPT Inc. Sales Department at:

Phone: (425) 353-3010
Fax: (425) 353-4030
E-mail: vptsales@vpt-inc.com

All information contained in this datasheet is believed to be accurate, however, no responsibility is assumed for possible errors or omissions. The products or specifications contained herein are subject to change without notice.