



# DVEHF2800T Series

## HIGH RELIABILITY HYBRID DC-DC CONVERTERS WITH INTEGRAL EMI FILTER

### DESCRIPTION

The DVEHF series of high reliability DC-DC converters is operable over the full military (-55 °C to +125 °C) temperature range with no power derating. Unique to the DVEHF series are robust and effective input and output filters which provide dramatically reduced input and output noise performance when compared to other manufacturers competing devices. Operating at a nominal fixed frequency of 450 kHz, these regulated, isolated units utilize a high speed magnetic feedback design and well controlled undervoltage lockout circuitry to eliminate slow start-up problems.

These converters are designed and manufactured in a facility qualified to ISO9001 and certified to MIL-PRF-38534 and MIL-STD-883.

This product may incorporate one or more of the following U.S. patents:

5,784,266  
5,790,389  
5,963,438  
5,999,433  
6,005,780  
6,084,792  
6,118,673

### FEATURES

- High Reliability
- Very Low Output Noise
- Wide Input Voltage Range: 15 to 50 Volts per MIL-STD-704
- Up to 10 Watts Output Power
- Fault Tolerant Magnetic Feedback Circuit
- NO Use of Optoisolators
- Undervoltage Lockout
- Indefinite Short Circuit Protection
- Current Limit Protection
- Industry Standard Pinout
- High Input Transient Voltage: 80 Volts for 1 sec per MIL-STD-704A
- Precision Seam Seal Hermetic Package
- Custom Versions Available
- Additional Environmental Screening Available
- No External EMI Filter Required
- Meets MIL-STD-461C and MIL-STD-461D EMC Requirements
- Protects Against Conducted Susceptibility Specified in MIL-STD-461C, SC01 and CS02
- Non-flanged Version Available
- MIL-PRF-38534 Element Evaluated Components

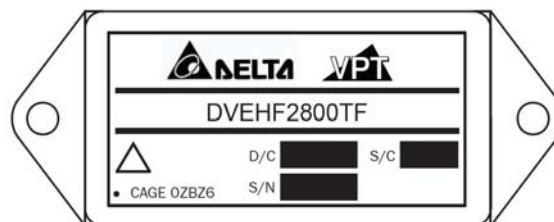

**Figure 1** – DVEHF2800T/DVEHF2800TF DC-DC Converter  
(Exact marking may differ from that shown)

SPECIFICATIONS ( $T_{CASE} = -55^{\circ}\text{C}$  to  $+125^{\circ}\text{C}$ ,  $V_{IN} = +28\text{V} \pm 5\%$ , Full Load<sup>5</sup>, Unless Otherwise Specified)

### ABSOLUTE MAXIMUM RATINGS

Input Voltage (Continuous)	50 V <sub>DC</sub>	Junction Temperature Rise to Case	+15°C
Input Voltage (Transient, 1 second)	80 Volts	Storage Temperature	-65°C to +150°C
Output Power	10 Watts	Lead Solder Temperature (10 seconds)	270°C
Power Dissipation (Full Load, $T_{CASE} = +125^{\circ}\text{C}$ )	5.0 Watts	Weight (Maximum)	50 Grams

Parameter	Conditions	DVEHF28512T			DVEHF28515T			Units	
		Min	Typ	Max	Min	Typ	Max		
<b>STATIC</b>									
INPUT Voltage	Continuous	15	28	50	15	28	50	V	
	Transient, 1 sec <sup>4</sup>	-	-	80	-	-	80	V	
Current	Inhibited	-	3.5	6.0	-	3.5	6.0	mA	
	No Load	-	-	70	-	-	70	mA	
Inhibit Pin Input <sup>4</sup>		0	-	1.5	0	-	1.5	V	
Inhibit Pin Open Circuit Voltage <sup>4</sup>		9.0	11.0	13.0	9.0	11.0	13.0	V	
UVLO Turn On		8.0	-	12.0	8.0	-	12.0	V	
UVLO Turn Off <sup>4</sup>		4.0	-	8.0	4.0	-	8.0	V	
OUTPUT Voltage	$V_{MAIN}$ $\pm V_{AUX}$	$T_{CASE} = 25^{\circ}\text{C}$	4.95	5.0	5.05	4.95	5.0	5.05	V
			11.88	12.0	12.12	14.85	15.0	15.15	V
	$V_{MAIN}$ $\pm V_{AUX}$	$T_{CASE} = -55^{\circ}\text{C}$ to $+125^{\circ}\text{C}$	4.925	5.0	5.075	4.925	5.0	5.075	V
			11.4	12.0	12.6	14.25	15.0	15.75	V
Power <sup>4</sup>	Total	0	-	10	0	-	10	W	
	$V_{MAIN}$	0.15	-	5.0	0.15	-	5.0	W	
	$\pm V_{AUX}$ <sup>6</sup>	0	-	3.5	0	-	3.5	W	
Current <sup>3</sup>	$V_{MAIN}$	0	-	1.0	0	-	1.0	A	
	$\pm V_{AUX}$	0	-	0.29	0	-	0.23	A	
Ripple Voltage	$V_{MAIN}$	-	15	50	-	15	50	mV <sub>p-p</sub>	
	$\pm V_{AUX}$	-	15	50	-	15	50	mV <sub>p-p</sub>	
Line Regulation	$V_{MAIN}$	-	10	20	-	10	20	mV	
	$\pm V_{AUX}$	-	15	50	-	15	50	mV	
Load Regulation	$V_{MAIN}$	-	5	20	-	5	20	mV	
	$\pm V_{AUX}$	-	10	50	-	10	50	mV	
Cross Regulation	$\pm V_{AUX}$	-	-	50	-	-	50	mV	
EFFICIENCY	Full Load <sup>5</sup>	67	72	-	67	72	-	%	
LOAD FAULT POWER DISSIPATION	Overload <sup>4</sup>	-	-	7.5	-	-	7.5	W	
	Short Circuit	-	-	7.5	-	-	7.5	W	
CAPACITIVE LOAD <sup>4</sup>		-	-	500	-	-	500	$\mu\text{F}$	
SWITCHING FREQUENCY		350	450	550	350	450	550	kHz	
ISOLATION	500 V <sub>DC</sub> , $T_{CASE} = 25^{\circ}\text{C}$	100	-	-	100	-	-	M $\Omega$	
MTBF (MIL-HDBK-217F)	AIF @ $T_C = 55^{\circ}\text{C}$	-	350	-	-	350	-	kHrs	

SPECIFICATIONS ( $T_{CASE} = -55^{\circ}\text{C}$  to  $+125^{\circ}\text{C}$ ,  $V_{IN} = +28\text{V} \pm 5\%$ , Full Load<sup>5</sup>, Unless Otherwise Specified)

### ABSOLUTE MAXIMUM RATINGS

Input Voltage (Continuous)	50 $V_{DC}$	Junction Temperature Rise to Case	+15°C
Input Voltage (Transient, 1 second)	80 Volts	Storage Temperature	-65°C to +150°C
Output Power	10 Watts	Lead Solder Temperature (10 seconds)	270°C
Power Dissipation (Full Load, $T_{CASE} = +125^{\circ}\text{C}$ )	5.0 Watts	Weight (Maximum)	50 Grams

Parameter	Conditions	DVEHF28512T			DVEHF28515T			Units	
		Min	Typ	Max	Min	Typ	Max		
<b>DYNAMIC</b>									
Load Step Output Transient	$V_{MAIN}$	Half Load to Full Load	-	200	500	-	200	500	mV <sub>PK</sub>
	$\pm V_{AUX}$		-	100	400	-	100	400	mV <sub>PK</sub>
Load Step Recovery <sup>2</sup>	$V_{MAIN}$		-	200	500	-	200	500	$\mu\text{Sec}$
	$\pm V_{AUX}$		-	200	500	-	200	500	$\mu\text{Sec}$
Line Step Output Transient <sup>4</sup>	$V_{MAIN}$	$V_{IN} = 16\text{V}$ to $40\text{V}$	-	200	600	-	200	600	mV <sub>PK</sub>
	$\pm V_{AUX}$		-	50	100	-	50	100	mV <sub>PK</sub>
Line Step Recovery <sup>2, 4</sup>	$V_{MAIN}$		-	200	500	-	200	500	$\mu\text{Sec}$
	$\pm V_{AUX}$		-	200	500	-	200	500	$\mu\text{Sec}$
Turn On Delay			-	25	35	-	25	35	mSec
Turn On Overshoot	$V_{MAIN}$	$V_{IN} = 0\text{V}$ to $28\text{V}$	-	-	25	-	-	25	mV <sub>PK</sub>
	$\pm V_{AUX}$		-	-	50	-	-	50	mV <sub>PK</sub>

- Notes:
1. This note intentionally not used.
  2. Time for output voltage to settle within 1% of its nominal value.
  3. Derate linearly to 0 at 135°C.
  4. Verified by qualification testing.
  5. 5.0W on  $V_{MAIN}$  and 2.5W on  $\pm V_{AUX}$ .
  6. Up to 70% of the total auxiliary power or current can be drawn from either of the auxiliary outputs.
  7. 5% load to full load at -55°C.

BLOCK DIAGRAM

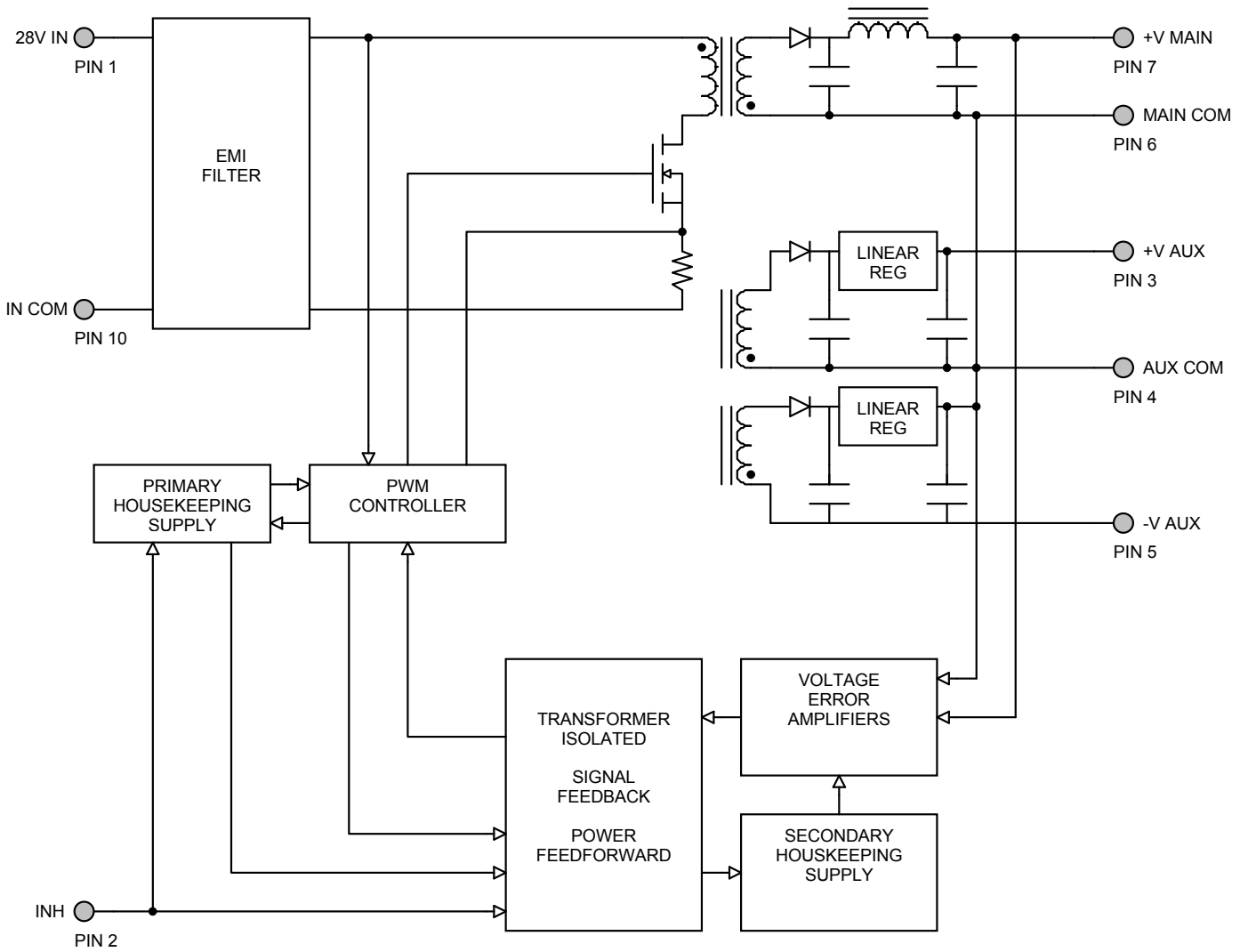

Figure 2

CONNECTION DIAGRAM

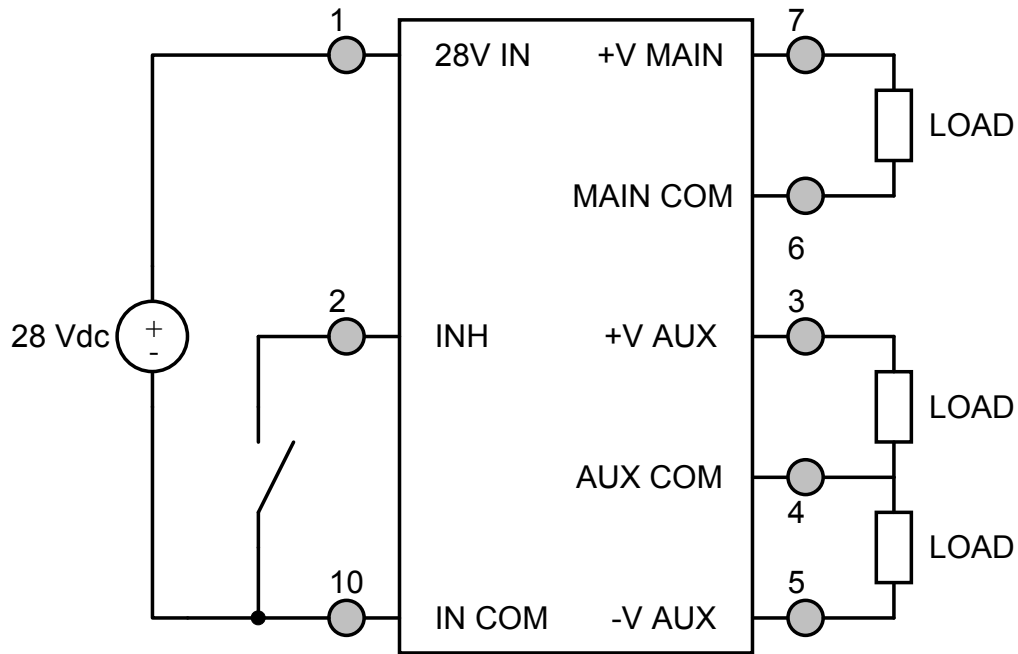

Figure 3

INHIBIT DRIVE CONNECTION DIAGRAMS

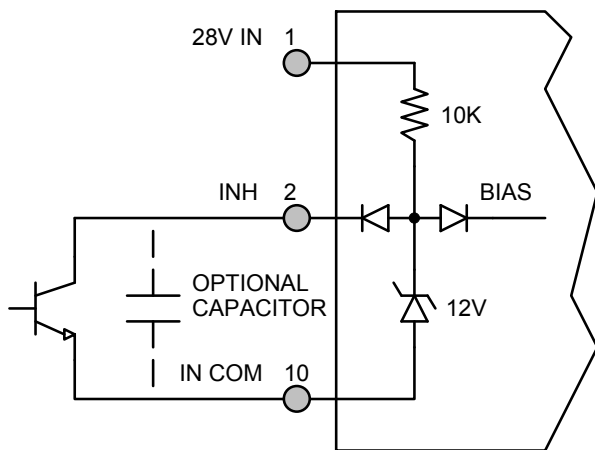

Figure 4 – Internal Inhibit Circuit and Recommended Drive  
(Shown with optional capacitor for turn-on delay)

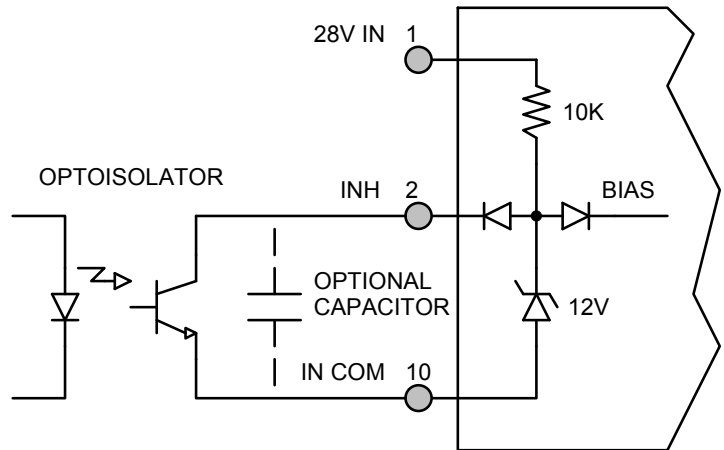
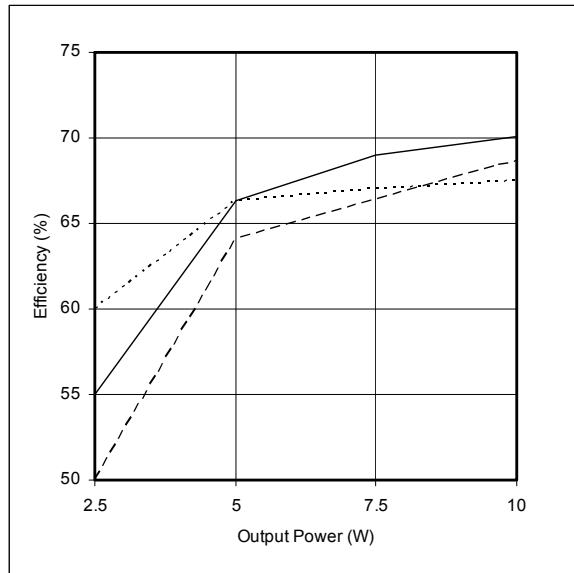
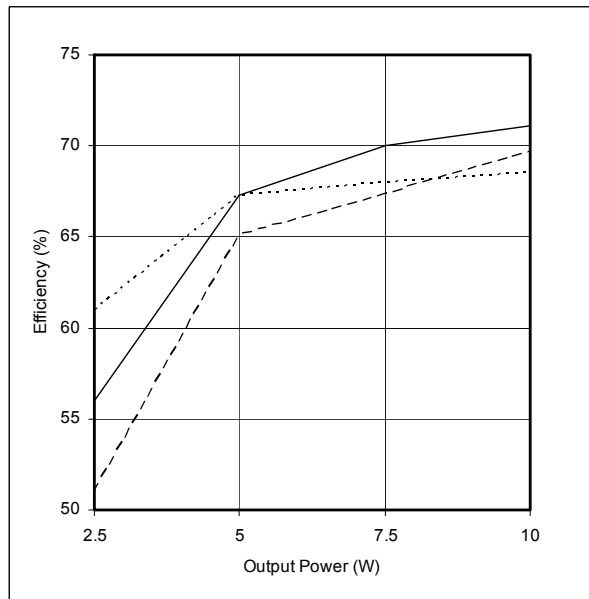

Figure 5 – Isolated Inhibit Drive  
(Shown with optional capacitor for turn-on delay)

EFFICIENCY PERFORMANCE CURVES ( $T_{CASE} = 25^{\circ}C$ )



**Figure 7 – DVEHF28512T**  
Efficiency (%) vs. Output Power (W)



**Figure 8 – DVEHF28515T**  
Efficiency (%) vs. Output Power (W)

EMI PERFORMANCE CURVES

( $T_{CASE} = 25^{\circ}C$ ,  $V_{IN} = +28V \pm 5\%$ , Full Load, Unless Otherwise Specified)

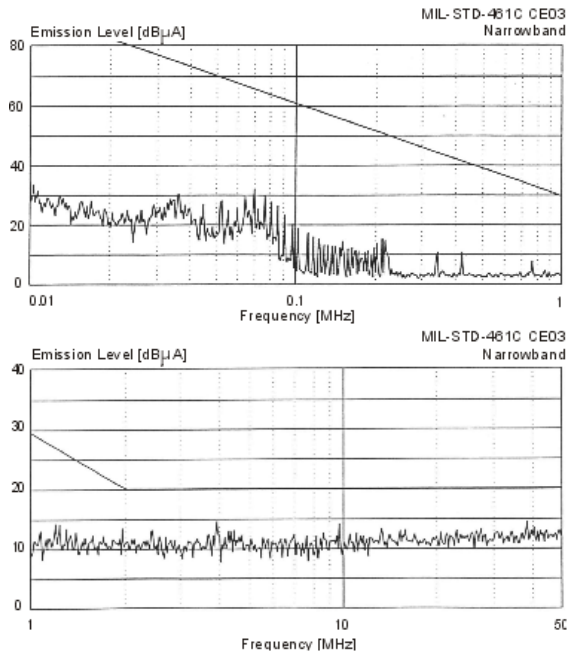

Figure 9 – MIL-STD-461C  
DVEHF2800T

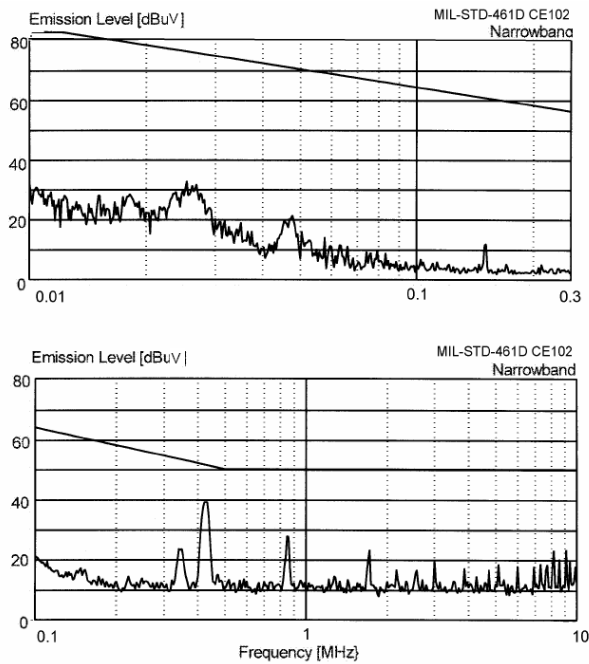
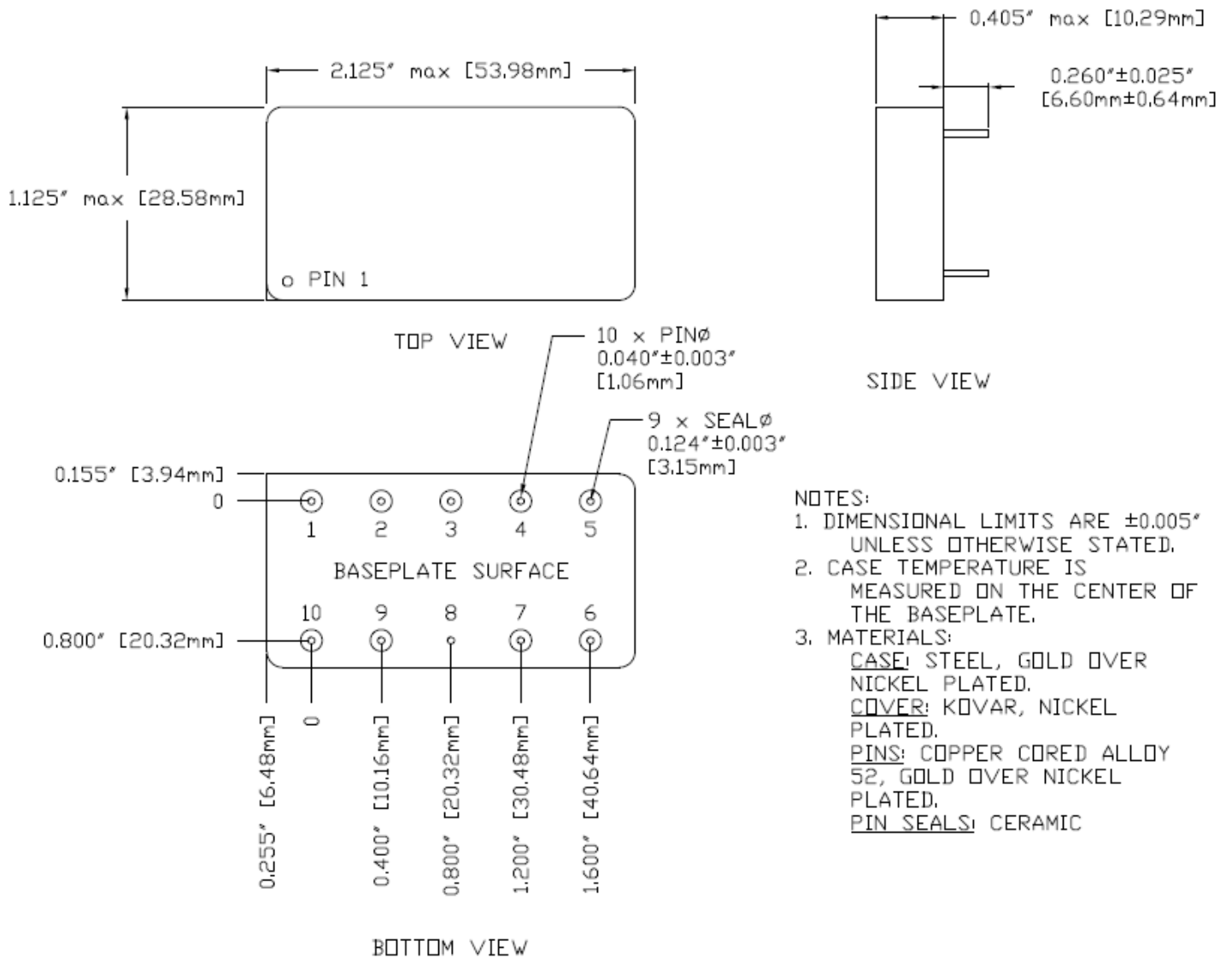

Figure 10 – MIL-STD-461D  
DVEHF2800T

PACKAGE SPECIFICATIONS (NON-FLANGED, SEAM SEAL)



PIN	FUNCTION	PIN	FUNCTION
1	28V IN	6	MAIN COM
2	INHIBIT	7	+V MAIN
3	+V AUX	8	CASE
4	AUX COM	9	N/C
5	-V AUX	10	IN COM

Figure 11 – Non-Flanged, Seam Seal Package and Pinout



## PACKAGE PIN DESCRIPTION

Pin	Function	Description
1	28V IN	Positive Input Voltage Connection
2	INHIBIT	Logic Low = Disabled Output. Connecting the inhibit pin to input common causes converter shutdown. Logic High = Enabled Output. Unconnected or open collector TTL.
3	+V AUX	Positive Auxiliary Output Voltage Connection
4	AUX COM	Auxiliary Output Common Connection
5	-V AUX	Negative Auxiliary Output Voltage Connection
6	MAIN COM	Main Output Common Connection
7	+V MAIN	Positive Main Output Voltage Connection
8	CASE	Case Connection
9	N/C	No Connection
10	IN COM	Input Common Connection

ENVIRONMENTAL SCREENING (100% Tested Per MIL-STD-883 as referenced to MIL-PRF-38534)

Screening	MIL-STD-883	Standard (No Suffix)	Extended /ES
Non-Destructive Bond Pull	Method 2023	•	•
Internal Visual	Method 2017, 2032 Internal Procedure	•	•
Temperature Cycling	Method 1010, -55°C to 125°C		•
Constant Acceleration	Method 2001, 500g, Y1 Direction		•
Burn-In	96 hours at +125°C 24 hours at +125°C	•	•
Final Electrical	100% at 25°C	•	•
Hermeticity	Method 1014, Fine Leak, Condition A Method 1014, Gross Leak, Condition C Dip ( $1 \times 10^{-3}$ )	•	• •
External Visual	Method 2009	•	•

