



DVTR2800D Series

HIGH RELIABILITY HYBRID DC-DC CONVERTERS

DESCRIPTION

The DVTR series of high reliability DC-DC converters is operable over the full military (-55 °C to +125 °C) temperature range with no power derating. Unique to the DVTR series are robust and effective input and output filters which provide dramatically reduced input and output noise performance when compared to other manufacturers competing devices. Operating at a nominal fixed frequency of 500 kHz, these regulated, isolated units utilize a high speed magnetic feedback design and well controlled undervoltage lockout circuitry to eliminate slow start-up problems.

These converters are designed and manufactured in a facility qualified to ISO9001 and certified to MIL-PRF-38534 and MIL-STD-883.

This product may incorporate one or more of the following U.S. patents:

- 5,784,266
- 5,790,389
- 5,963,438
- 5,999,433
- 6,005,780
- 6,084,792
- 6,118,673

FEATURES

- High Reliability
- Very Low Output Noise
- Wide Input Voltage Range: 15 to 50 Volts per MIL-STD-704
- Up to 40 Watts Output Power
- Fault Tolerant Magnetic Feedback Circuit
- NO Use of Optoisolators
- Undervoltage Lockout
- Indefinite Short Circuit Protection
- Current Limit Protection
- Industry Standard Pinout
- High Input Transient Voltage: 80 Volts for 1 sec per MIL-STD-704A
- Precision Seam Welded Hermetic Package
- High Power Density: > 40 W/in³
- Custom Versions Available
- Additional Environmental Screening Available
- Meets MIL-STD-461 Revisions C, D, E and F EMC Requirements When Used With VPT's EMI Filters
- Flanged and Non-flanged Versions Available.
- MIL-PRF-38534 Element Evaluated Components
- Space Applications should consider VPT's "S" Series of Radiation Tolerant Power Conversion Devices. Contact VPT for details.

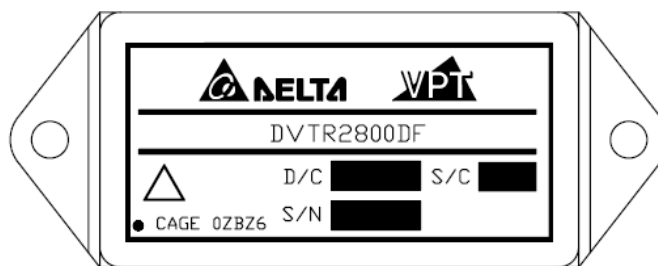

Figure 1 – DVTR2800D / DVTR2800DF DC-DC Converter
(Exact marking may differ from that shown)

SPECIFICATIONS ($T_{CASE} = -55^{\circ}\text{C}$ to $+125^{\circ}\text{C}$, $V_{IN} = +28\text{V} \pm 5\%$, Full Load⁵, Unless Otherwise Specified)

ABSOLUTE MAXIMUM RATINGS

Input Voltage (Continuous)	50 V _{DC}	Junction Temperature Rise to Case	+15°C
Input Voltage (Transient, 1 second)	80 Volts	Storage Temperature	-65°C to +150°C
Output Power ¹	40 Watts	Lead Solder Temperature (10 seconds)	270°C
Power Dissipation (Full Load, $T_{CASE} = +125^{\circ}\text{C}$)	13 Watts	Weight (Maximum) (Un-Flanged / Flanged)	(52 / 55) Grams
ESD Rating per MIL-PRF-38534	3A		

Parameter	Conditions	DVTR2805D			DVTR2808D			Units
		Min	Typ	Max	Min	Typ	Max	
STATIC								
INPUT Voltage ⁴	Continuous	15	28	50	15	28	50	V
	Transient, 1 sec	-	-	80	-	-	80	V
Current	Inhibited	-	4	6	-	4	6	mA
	No Load	-	60	90	-	60	90	mA
Ripple Current	Full Load ⁵ , 20Hz to 10MHz	-	30	50	-	30	50	mA _{p-p}
Inhibit Pin Input ⁴		0	-	1.5	0	-	1.5	V
Inhibit Pin Open Circuit Voltage ⁴		9.0	11.0	13.0	9.0	11.0	13.0	V
UVLO Turn On		12.0	-	14.8	12.0	-	14.8	V
UVLO Turn Off ⁴		11.0	-	14.5	11.0	-	14.5	V
OUTPUT Voltage ⁵	+V _{OUT} $T_{CASE} = 25^{\circ}\text{C}$	4.95	5.0	5.05	7.92	8.0	8.08	V
	+V _{OUT} $T_{CASE} = -55^{\circ}\text{C}$ to $+125^{\circ}\text{C}$	4.925	5.0	5.075	7.88	8.0	8.12	V
	-V _{OUT} $T_{CASE} = 25^{\circ}\text{C}$	4.80	5.0	5.20	7.80	8.0	8.20	V
	-V _{OUT} $T_{CASE} = -55^{\circ}\text{C}$ to $+125^{\circ}\text{C}$	4.70	5.0	5.30	7.76	8.0	8.24	V
Power ^{3,6}	Total	0	-	30	0	-	35	W
	$\pm V_{OUT}$ Either Output	0	-	21	0	-	25	W
Current ^{3,6}	$\pm V_{OUT}$ Either Output	0	-	4.2	0	-	3.12	A
Ripple Voltage	$\pm V_{OUT}$ Full Load ⁵ , 20Hz to 10MHz	-	30	60	-	40	60	mV _{p-p}
Line Regulation	+V _{OUT} $V_{IN} = 16\text{V}$ to 40V	-	2	20	-	2	20	mV
	-V _{OUT} $V_{IN} = 16\text{V}$ to 40V	-	25	200	-	35	200	mV
Load Regulation	+V _{OUT} No Load to Full Load ⁵	-	5	50	-	5	50	mV
	-V _{OUT} No Load to Full Load ^{5,7}	-	30	200	-	30	200	mV
Cross Regulation	-V _{OUT} +Load 70%, -Load 30% +Load 30%, -Load 70%	-	360	650	-	450	650	mV
EFFICIENCY	Full Load ⁵	73	79	-	74	79	-	%
LOAD FAULT POWER DISSIPATION	Overload ⁴	-	-	16	-	-	15	W
	Short Circuit	-	-	16	-	-	15	W
CAPACITIVE LOAD ⁴	Either Output	-	-	500	-	-	500	μF
SWITCHING FREQUENCY		400	450	550	400	450	550	kHz
SYNC FREQUENCY RANGE	$V_H - V_L = 5\text{V}$, DC = 20-80%	500	-	600	500	-	600	kHz
ISOLATION	500 V _{DC} , $T_{CASE} = 25^{\circ}\text{C}$	100	-	-	100	-	-	M Ω
MTBF (MIL-HDBK-217F)	AIF @ $T_C = 55^{\circ}\text{C}$	-	413	-	-	413	-	kHrs

See notes next page.

SPECIFICATIONS ($T_{CASE} = -55^{\circ}\text{C}$ to $+125^{\circ}\text{C}$, $V_{IN} = +28\text{V} \pm 5\%$, Full Load⁵, Unless Otherwise Specified)

ABSOLUTE MAXIMUM RATINGS

Input Voltage (Continuous)	50 V _{DC}	Junction Temperature Rise to Case	+15°C
Input Voltage (Transient, 1 second)	80 Volts	Storage Temperature	-65°C to +150°C
Output Power ¹	40 Watts	Lead Solder Temperature (10 seconds)	270°C
Power Dissipation (Full Load, $T_{CASE} = +125^{\circ}\text{C}$)	13 Watts	Weight (Maximum) (Un-Flanged / Flanged)	(52 / 55) Grams
ESD Rating per MIL-PRF-38534	3A		

Parameter	Conditions	DVTR2805D			DVTR2808D			Units	
		Min	Typ	Max	Min	Typ	Max		
DYNAMIC									
Load Step Output Transient	$\pm V_{OUT}$	Half Load to Full Load	-	100	400	-	100	200	mV _{PK}
Load Step Recovery ²			-	100	350	-	50	100	μSec
Line Step Output Transient ⁴	$\pm V_{OUT}$	$V_{IN} = 16\text{V}$ to 40V	-	300	600	-	200	550	mV _{PK}
Line Step Recovery ^{2, 4}			-	300	500	-	250	500	μSec
Turn On Delay	$\pm V_{OUT}$	$V_{IN} = 0\text{V}$ to 28V	-	10	20	-	10	20	mSec
Turn On Overshoot			-	0	25	-	0	25	mV _{PK}

- Notes:
1. Dependant on output voltage.
 2. Time for output voltage to settle within 1% of its nominal value.
 3. Derate linearly to 0 at 135°C.
 4. Verified by qualification testing.
 5. Half load at +V_{OUT} and half load at -V_{OUT}.
 6. Up to 70% of the total power or current can be drawn from any one of the two outputs.
 7. 5% Load to Full Load at -55°C.

SPECIFICATIONS ($T_{CASE} = -55^{\circ}\text{C}$ to $+125^{\circ}\text{C}$, $V_{IN} = +28\text{V} \pm 5\%$, Full Load⁵, Unless Otherwise Specified)

ABSOLUTE MAXIMUM RATINGS

Input Voltage (Continuous)	50 V _{DC}	Junction Temperature Rise to Case	+15°C
Input Voltage (Transient, 1 second)	80 Volts	Storage Temperature	-65°C to +150°C
Output Power ¹	40 Watts	Lead Solder Temperature (10 seconds)	270°C
Power Dissipation (Full Load, $T_{CASE} = +125^{\circ}\text{C}$)	13 Watts	Weight (Maximum) (Un-Flanged / Flanged)	(52 / 55) Grams
ESD Rating per MIL-PRF-38534	3A		

Parameter	Conditions	DVTR2812D			DVTR2815D			Units
		Min	Typ	Max	Min	Typ	Max	
STATIC								
INPUT Voltage ⁴	Continuous	15	28	50	15	28	50	V
	Transient, 1 sec	-	-	80	-	-	80	V
Current	Inhibited	-	4	6	-	4	6	mA
	No Load	-	60	90	-	60	90	mA
Ripple Current	Full Load ⁵ , 20Hz to 10MHz	-	30	50	-	25	50	mA _{p-p}
Inhibit Pin Input ⁴		0	-	1.5	0	-	1.5	V
Inhibit Pin Open Circuit Voltage ⁴		9.0	11.0	13.0	9.0	11.0	13.0	V
UVLO Turn On		12.0	-	14.8	12.0	-	14.8	V
UVLO Turn Off ⁴		11.0	-	14.5	11.0	-	14.5	V
OUTPUT Voltage ⁵	+V _{OUT} $T_{CASE} = 25^{\circ}\text{C}$	11.88	12.0	12.12	14.85	15.0	15.15	V
	+V _{OUT} $T_{CASE} = -55^{\circ}\text{C}$ to $+125^{\circ}\text{C}$	11.82	12.0	12.18	14.70	15.0	15.30	V
	-V _{OUT} $T_{CASE} = 25^{\circ}\text{C}$	11.80	12.0	12.20	14.70	15.0	15.30	V
	-V _{OUT} $T_{CASE} = -55^{\circ}\text{C}$ to $+125^{\circ}\text{C}$	11.64	12.0	12.36	14.55	15.0	15.45	V
Power ^{3,6}	Total	0	-	40	0	-	40	W
	$\pm V_{OUT}$ Either Output	0	-	28	0	-	28	W
Current ^{3,6}	$\pm V_{OUT}$ Either Output	0	-	2.33	0	-	1.87	A
Ripple Voltage	$\pm V_{OUT}$ Full Load ⁵ , 20Hz to 10MHz	-	25	50	-	25	50	mV _{p-p}
Line Regulation	+V _{OUT} $V_{IN} = 16\text{V}$ to 40V	-	2	20	-	2	20	mV
	-V _{OUT} $V_{IN} = 16\text{V}$ to 40V	-	25	200	-	65	200	mV
Load Regulation	+V _{OUT} No Load to Full Load ⁵	-	2	50	-	2	50	mV
	-V _{OUT} No Load to Full Load ^{5,7}	-	20	200	-	35	200	mV
Cross Regulation	-V _{OUT} +Load 70%, -Load 30% +Load 30%, -Load 70%	-	430	650	-	420	650	mV
EFFICIENCY	Full Load ⁵	78	84	-	78	84	-	%
LOAD FAULT POWER DISSIPATION	Overload ⁴	-	-	14	-	-	14	W
	Short Circuit	-	-	14	-	-	14	W
CAPACITIVE LOAD ⁴	Either Output	-	-	500	-	-	500	μF
SWITCHING FREQUENCY		400	450	550	400	450	550	kHz
SYNC FREQUENCY RANGE	$V_H - V_L = 5\text{V}$, DC = 20-80%	500	-	600	500	-	600	kHz
ISOLATION	500 V _{DC} , $T_{CASE} = 25^{\circ}\text{C}$	100	-	-	100	-	-	M Ω
MTBF (MIL-HDBK-217F)	AIF @ $T_C = 55^{\circ}\text{C}$	-	413	-	-	413	-	kHrs

See notes next page.

SPECIFICATIONS ($T_{CASE} = -55^{\circ}\text{C}$ to $+125^{\circ}\text{C}$, $V_{IN} = +28\text{V} \pm 5\%$, Full Load⁵, Unless Otherwise Specified)

ABSOLUTE MAXIMUM RATINGS

Input Voltage (Continuous)	50 V _{DC}	Junction Temperature Rise to Case	+15°C
Input Voltage (Transient, 1 second)	80 Volts	Storage Temperature	-65°C to +150°C
Output Power ¹	40 Watts	Lead Solder Temperature (10 seconds)	270°C
Power Dissipation (Full Load, $T_{CASE} = +125^{\circ}\text{C}$)	13 Watts	Weight (Maximum) (Un-Flanged / Flanged)	(52 / 55) Grams
ESD Rating per MIL-PRF-38534	3A		

Parameter	Conditions	DVTR2812D			DVTR2815D			Units	
		Min	Typ	Max	Min	Typ	Max		
DYNAMIC									
Load Step Output Transient	$\pm V_{OUT}$	Half Load to Full Load	-	300	450	-	280	500	mV _{PK}
Load Step Recovery ²			-	120	400	-	100	300	μSec
Line Step Output Transient ⁴	$\pm V_{OUT}$	$V_{IN} = 16\text{V}$ to 40V $P_{OUT} = 30\text{W}$	-	500	900	-	500	900	mV _{PK}
Line Step Recovery ^{2, 4}			-	300	500	-	300	500	μSec
Turn On Delay	$\pm V_{OUT}$	$V_{IN} = 0\text{V}$ to 28V	-	10	20	-	10	20	mSec
Turn On Overshoot			-	0	50	-	0	50	mV _{PK}

- Notes:
1. Dependant on output voltage.
 2. Time for output voltage to settle within 1% of its nominal value.
 3. Derate linearly to 0 at 135°C.
 4. Verified by qualification testing.
 5. Half load at +V_{OUT} and half load at -V_{OUT}.
 6. Up to 70% of the total power or current can be drawn from any one of the two outputs.
 7. 5% Load to Full Load at -55°C.

SPECIFICATIONS ($T_{CASE} = -55^{\circ}\text{C}$ to $+125^{\circ}\text{C}$, $V_{IN} = +28\text{V} \pm 5\%$, Full Load⁵, Unless Otherwise Specified)

ABSOLUTE MAXIMUM RATINGS

Input Voltage (Continuous)	50 V _{DC}	Junction Temperature Rise to Case	+15°C
Input Voltage (Transient, 1 second)	80 Volts	Storage Temperature	-65°C to +150°C
Output Power ¹	40 Watts	Lead Solder Temperature (10 seconds)	270°C
Power Dissipation (Full Load, $T_{CASE} = +125^{\circ}\text{C}$)	13 Watts	Weight (Maximum) (Un-Flanged / Flanged)	(52 / 55) Grams
ESD Rating per MIL-PRF-38534	3A		

Parameter	Conditions	DVTR2818D			Units
		Min	Typ	Max	
STATIC					
INPUT Voltage ⁴	Continuous	15	28	50	V
	Transient, 1 sec	-	-	80	V
Current	Inhibited	-	4	6	mA
	No Load	-	60	90	mA
Ripple Current	Full Load ⁵ , 20Hz to 10MHz	-	30	50	mA _{p-p}
Inhibit Pin Input ⁴		0	-	1.5	V
Inhibit Pin Open Circuit Voltage ⁴		9.0	11.0	13.0	V
UVLO Turn On		12.0	-	14.8	V
UVLO Turn Off ⁴		11.0	-	14.5	V
OUTPUT Voltage ⁵	+V _{OUT} $T_{CASE} = 25^{\circ}\text{C}$	17.82	18.0	18.18	V
	+V _{OUT} $T_{CASE} = -55^{\circ}\text{C}$ to $+125^{\circ}\text{C}$	17.64	18.0	18.36	V
	-V _{OUT} $T_{CASE} = 25^{\circ}\text{C}$	17.64	18.0	18.36	V
	-V _{OUT} $T_{CASE} = -55^{\circ}\text{C}$ to $+125^{\circ}\text{C}$	17.46	18.0	18.54	V
Power ^{3,6}	Total	-	-	40	W
	$\pm V_{OUT}$ Either Output	-	-	28	W
Current ^{3,6}	$\pm V_{OUT}$ Either Output	-	-	1.56	A
Ripple Voltage	$\pm V_{OUT}$ Full Load ⁵ , 20Hz to 10MHz	-	25	50	mV _{p-p}
Line Regulation	+V _{OUT} $V_{IN} = 16\text{V}$ to 40V	-	2	20	mV
	-V _{OUT} $V_{IN} = 16\text{V}$ to 40V	-	80	200	mV
Load Regulation	+V _{OUT} No Load to Full Load ⁵	-	2	50	mV
	-V _{OUT} No Load to Full Load ^{5,7}	-	45	200	mV
Cross Regulation	-V _{OUT} +Load 70%, -Load 30% +Load 30%, -Load 70%	-	420	650	mV
EFFICIENCY	Full Load ⁵	78	83	-	%
LOAD FAULT POWER DISSIPATION	Overload ⁴	-	-	14	W
	Short Circuit	-	-	14	W
CAPACITIVE LOAD ⁴	Either Output	-	-	300	μF
SWITCHING FREQUENCY		400	450	550	kHz
SYNC FREQUENCY RANGE	$V_H - V_L = 5\text{V}$, DC = 20-80%	500	-	600	kHz
ISOLATION	500 V _{DC} , $T_{CASE} = 25^{\circ}\text{C}$	100	-	-	M Ω
MTBF (MIL-HDBK-217F)	AIF @ $T_C = 55^{\circ}\text{C}$	-	413	-	kHrs

See notes next page.

SPECIFICATIONS ($T_{CASE} = -55^{\circ}\text{C}$ to $+125^{\circ}\text{C}$, $V_{IN} = +28\text{V} \pm 5\%$, Full Load⁵, Unless Otherwise Specified)

ABSOLUTE MAXIMUM RATINGS

Input Voltage (Continuous)	50 V_{DC}	Junction Temperature Rise to Case	+15°C
Input Voltage (Transient, 1 second)	80 Volts	Storage Temperature	-65°C to +150°C
Output Power ¹	40 Watts	Lead Solder Temperature (10 seconds)	270°C
Power Dissipation (Full Load, $T_{CASE} = +125^{\circ}\text{C}$)	13 Watts	Weight (Maximum) (Un-Flanged / Flanged)	(52 / 55) Grams
ESD Rating per MIL-PRF-38534	3A		

Parameter	Conditions	DVTR2818D			Units	
		Min	Typ	Max		
DYNAMIC						
Load Step Output Transient	$\pm V_{OUT}$	Half Load to Full Load	-	250	500	mV _{PK}
Load Step Recovery ²			-	100	250	μSec
Line Step Output Transient ⁴	$\pm V_{OUT}$	$V_{IN} = 16\text{V}$ to 40V	-	1200	2200	mV _{PK}
Line Step Recovery ^{2, 4}			-	350	500	μSec
Turn On Delay	$\pm V_{OUT}$	$V_{IN} = 0\text{V}$ to 28V	-	10	20	mSec
Turn On Overshoot			-	0	50	mV _{PK}

- Notes:
1. Dependant on output voltage.
 2. Time for output voltage to settle within 1% of its nominal value.
 3. Derate linearly to 0 at 135°C.
 4. Verified by qualification testing.
 5. Half load at $+V_{OUT}$ and half load at $-V_{OUT}$.
 6. Up to 70% of the total power or current can be drawn from any one of the two outputs.
 7. 5% Load to Full Load at -55°C.

BLOCK DIAGRAM

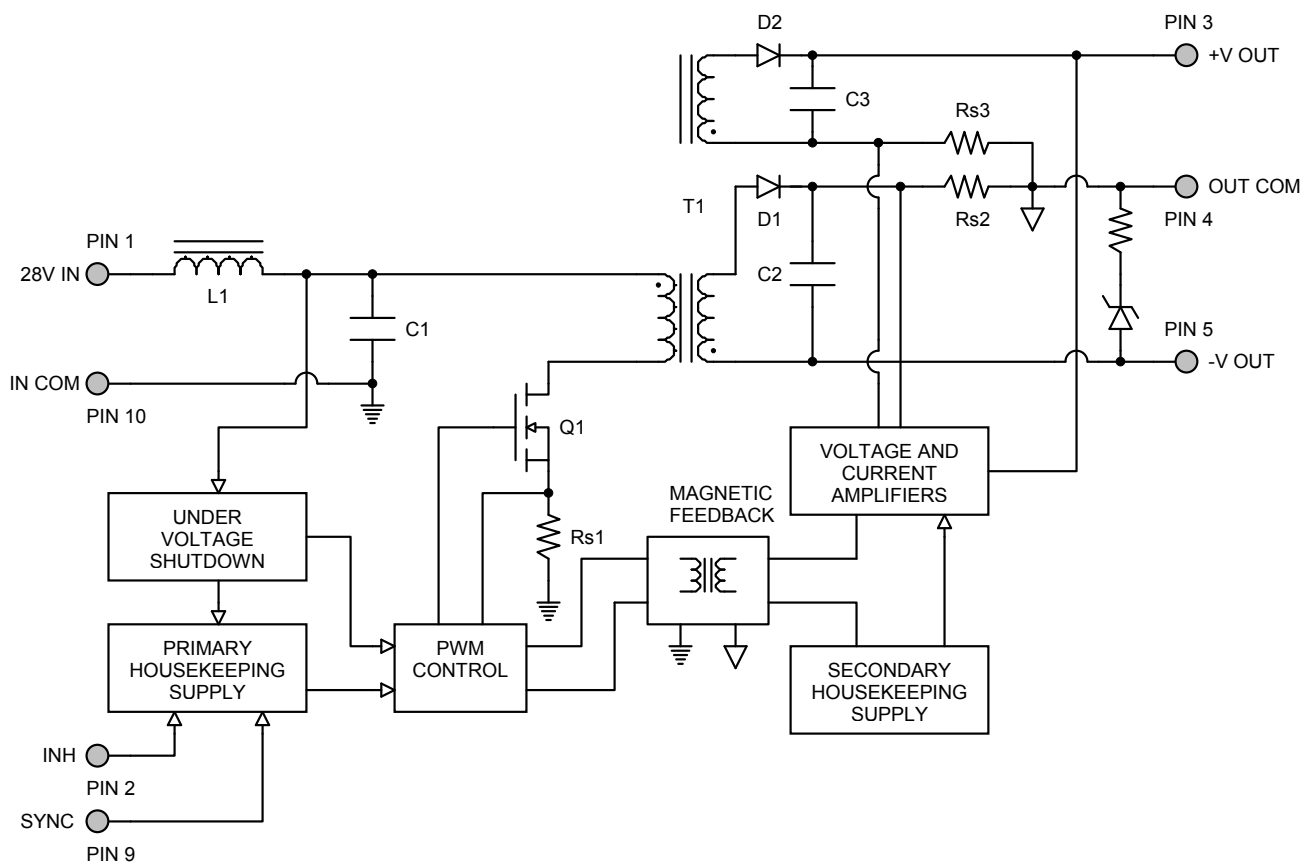

Figure 2

CONNECTION DIAGRAM

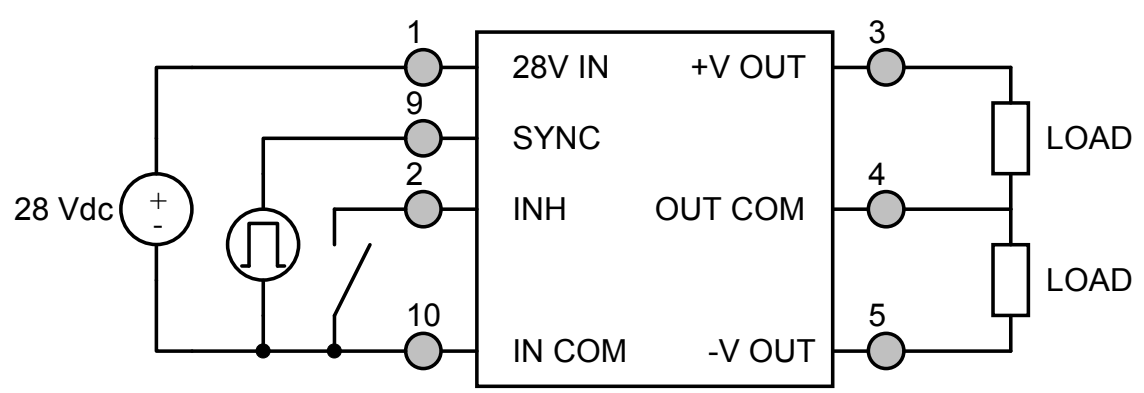

Figure 3

INHIBIT DRIVE CONNECTION DIAGRAMS

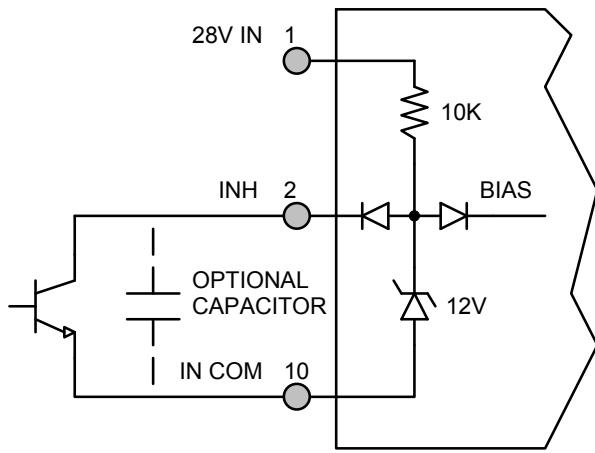

Figure 4 – Internal Inhibit Circuit and Recommended Drive
(Shown with optional capacitor for turn-on delay)

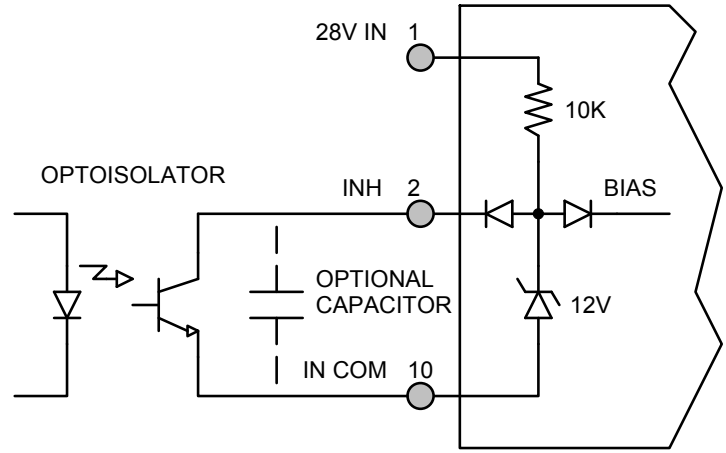

Figure 5 – Isolated Inhibit Drive
(Shown with optional capacitor for turn-on delay)

EMI FILTER HOOKUP DIAGRAM

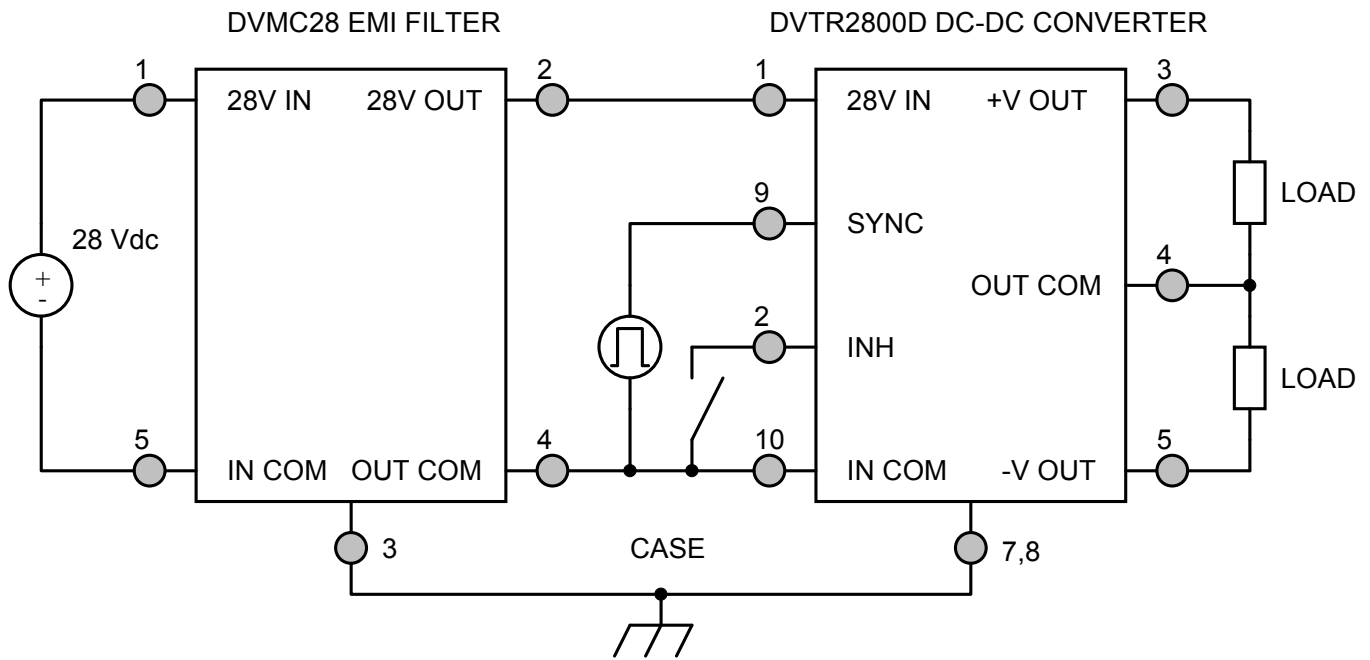

Figure 6 – Converter with EMI Filter

EFFICIENCY PERFORMANCE CURVES ($T_{CASE} = 25^{\circ}C$, Full Load, Unless Otherwise Specified)

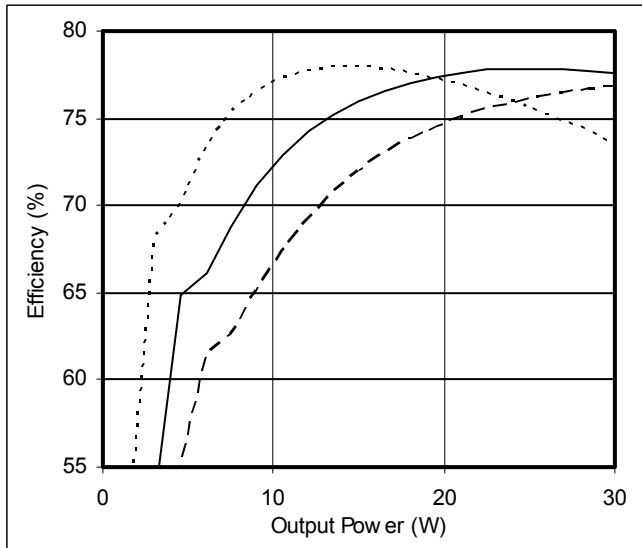
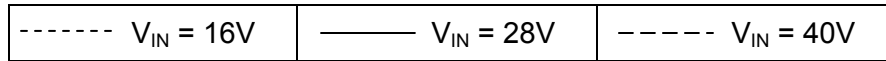

Figure 7 – DVTR2805D
Efficiency (%) vs. Output Power (W)

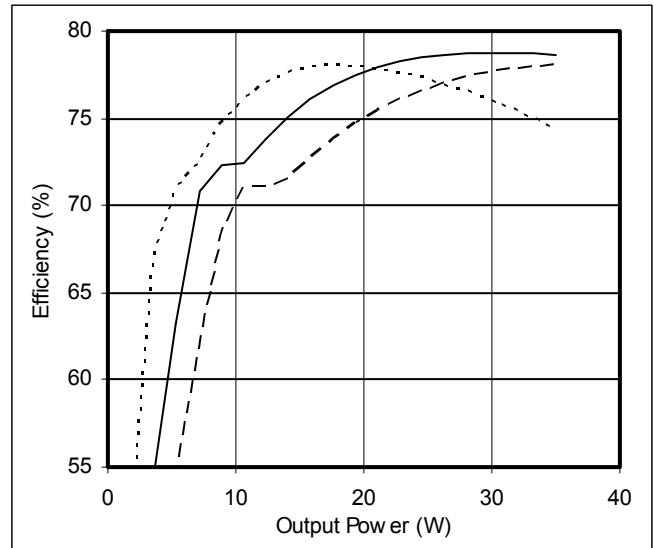

Figure 8 – DVTR2808D
Efficiency (%) vs. Output Power (W)

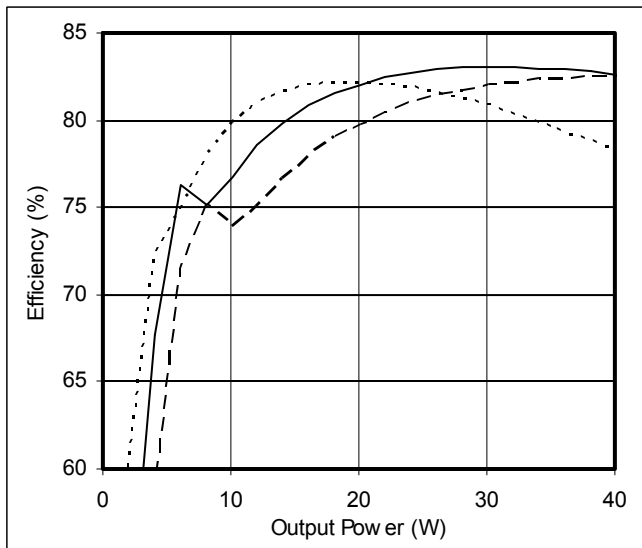

Figure 9 – DVTR2812D
Efficiency (%) vs. Output Power (W)

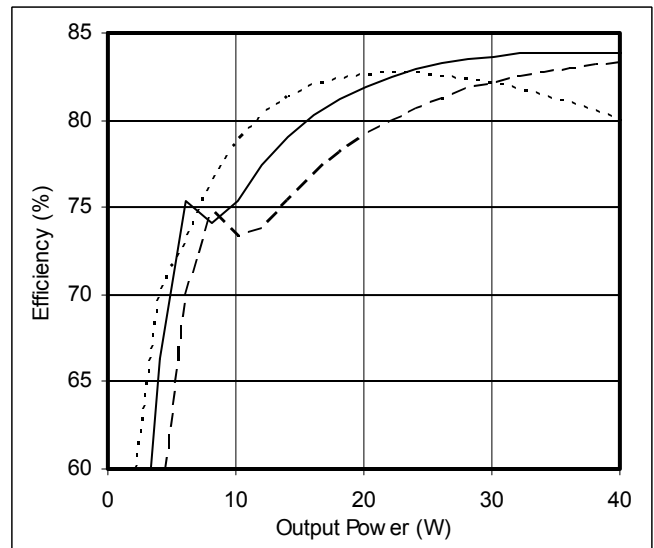

Figure 10 – DVTR2815D
Efficiency (%) vs. Output Power (W)

EFFICIENCY PERFORMANCE CURVES ($T_{CASE} = 25^{\circ}C$, Full Load, Unless Otherwise Specified)

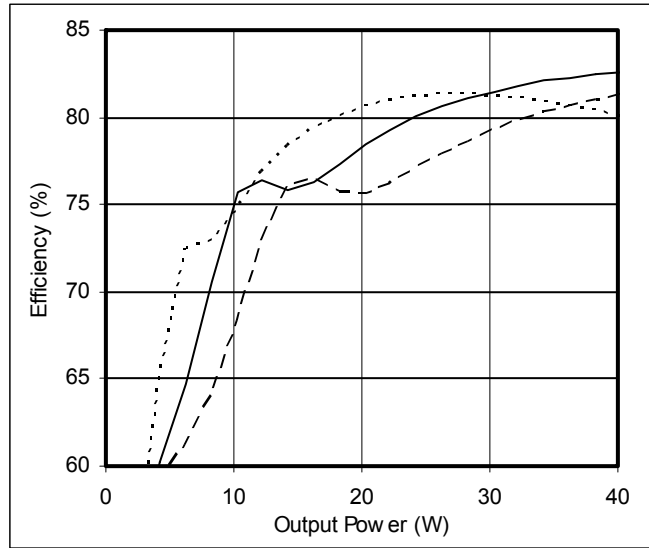

Figure 11 – DVTR2818D
Efficiency (%) vs. Output Power (W)

CROSS REGULATION CURVES ($T_{CASE} = 25^{\circ}C$, Full Load, Unless Otherwise Specified)

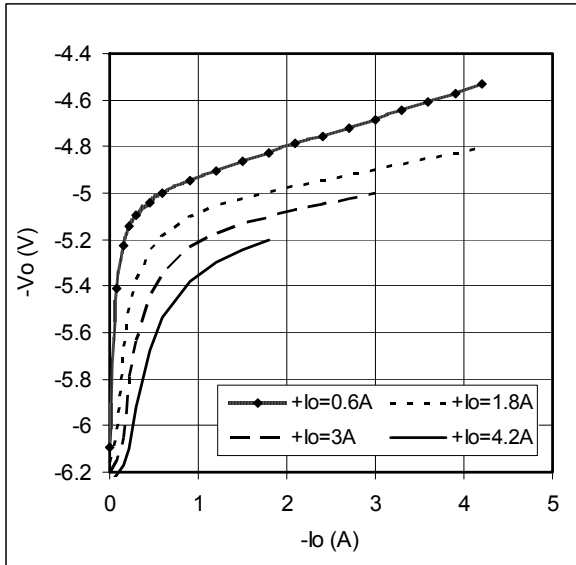
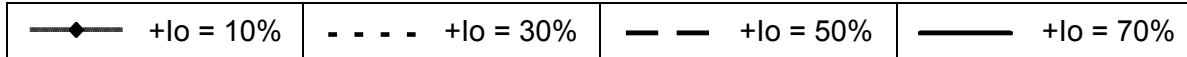

Figure 12 – DVTR2805D
-Vout (V) vs. -Iout (A)

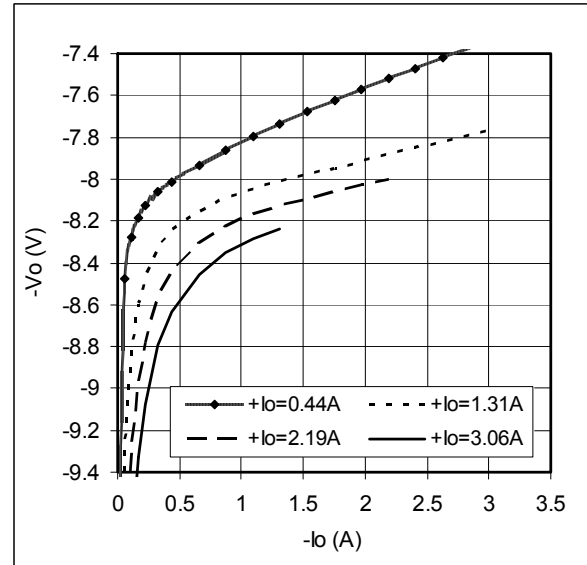

Figure 13 – DVTR2808D
-Vout (V) vs. -Iout (A)

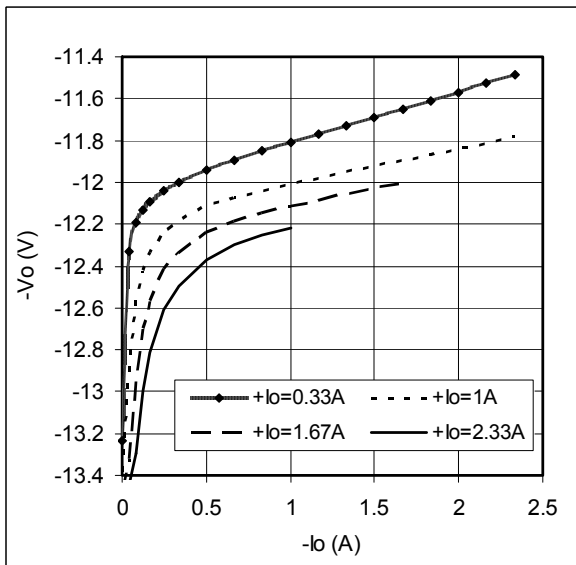

Figure 14 – DVTR2812D
-Vout (V) vs. -Iout (A)

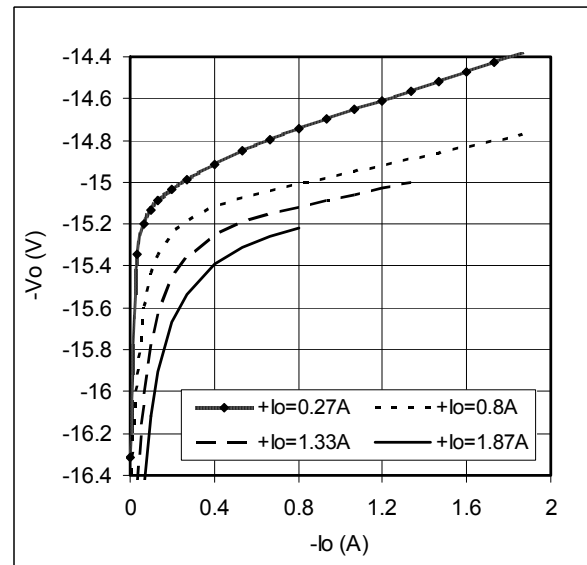

Figure 15 – DVTR2815D
-Vout (V) vs. -Iout (A)

CROSS REGULATION CURVES ($T_{CASE} = 25^{\circ}C$, Full Load, Unless Otherwise Specified)

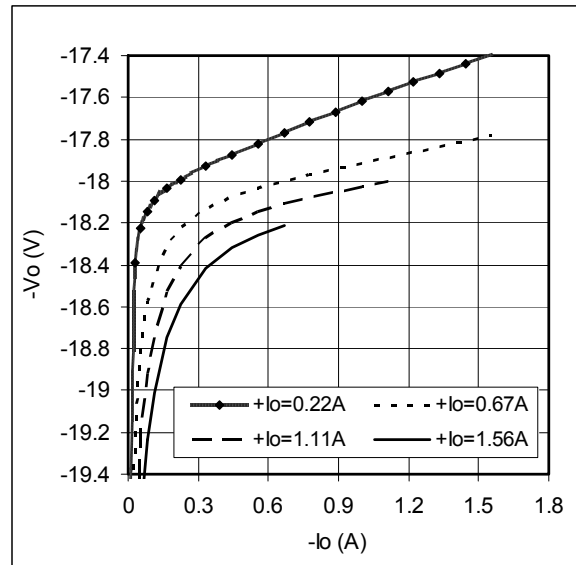
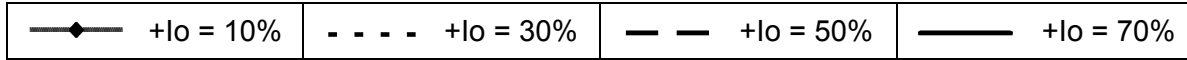

Figure 16 – DVTR2818D

-Vout (V) vs. -Iout (A)

EMI PERFORMANCE CURVES

($T_{CASE} = 25^{\circ}C$, $V_{IN} = +28V \pm 5\%$, Full Load, Unless Otherwise Specified)

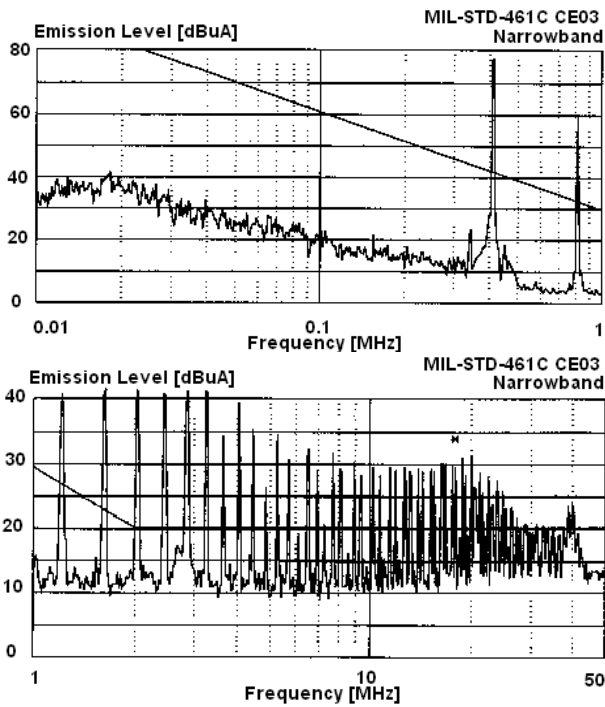

Figure 17 – DVTR2800D without EMI Filter

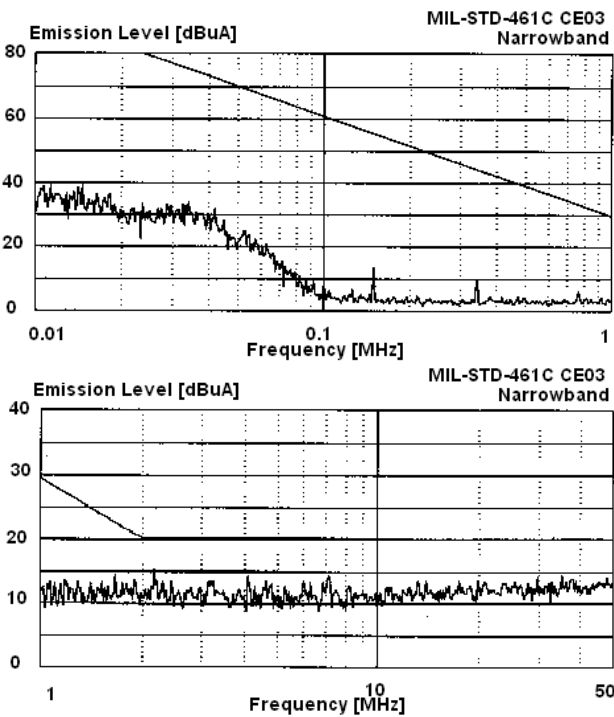
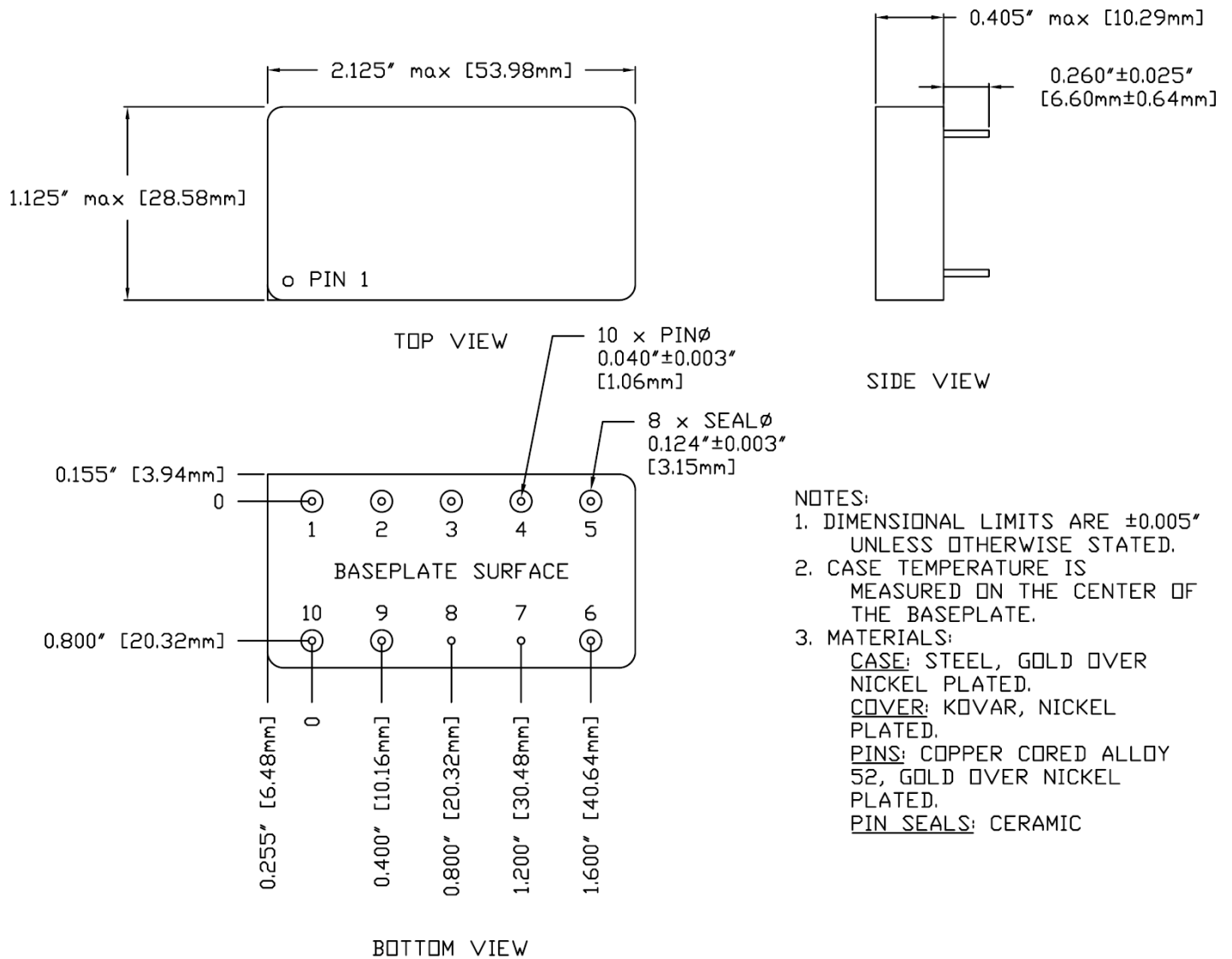

Figure 18 – DVTR2800D with EMI Filter

PACKAGE SPECIFICATIONS (NON-FLANGED, SEAM SEAL)



PIN	FUNCTION	PIN	FUNCTION
1	28V IN	6	CASE
2	INHIBIT	7	CASE
3	+V OUT	8	CASE
4	OUT COM	9	SYNC
5	-V OUT	10	IN COM

Figure 19 – Non-Flanged, Seam Seal Package and Pinout

PACKAGE SPECIFICATIONS (FLANGED, SEAM SEAL)

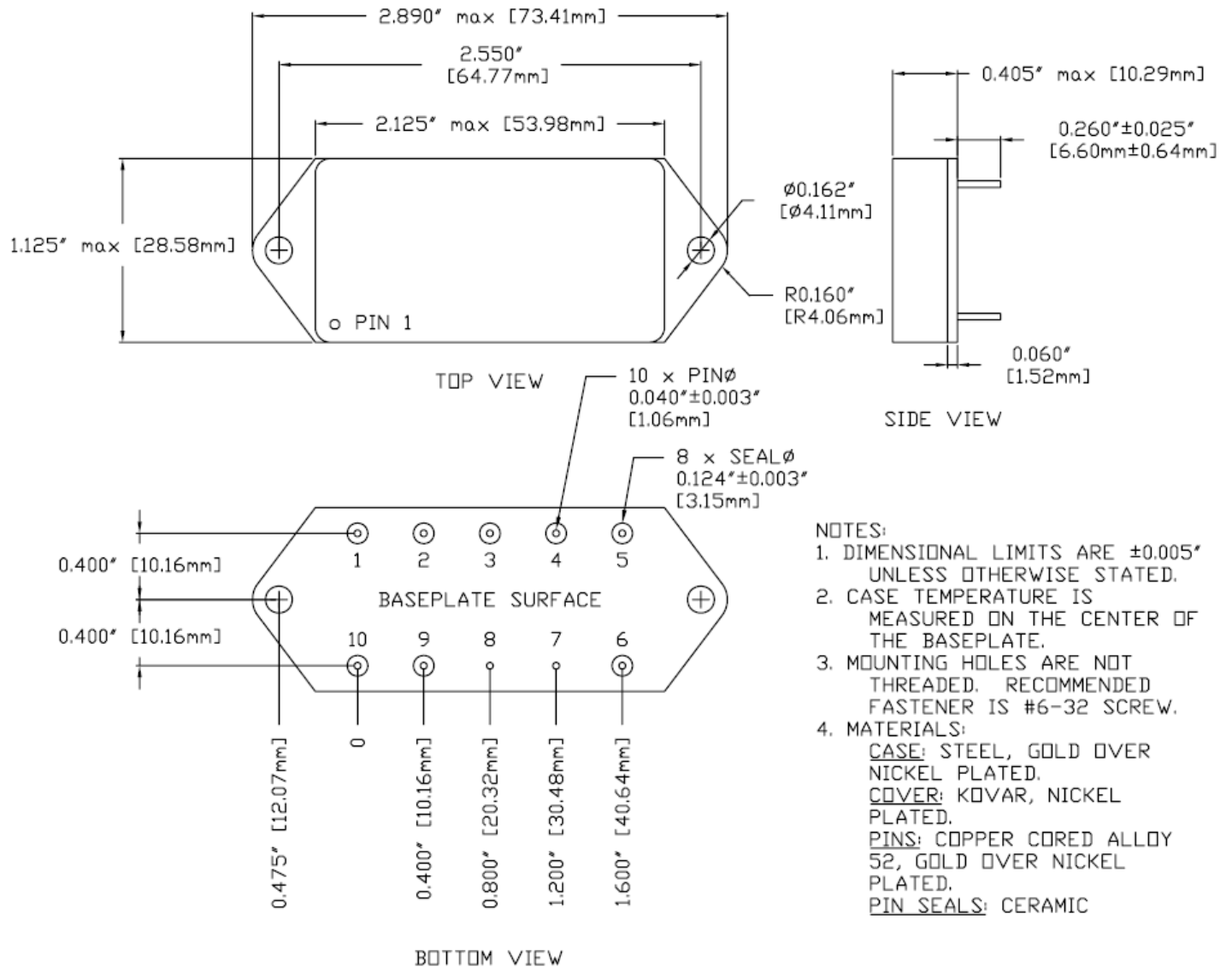

PIN	FUNCTION	PIN	FUNCTION
1	28V IN	6	CASE
2	INHIBIT	7	CASE
3	+V OUT	8	CASE
4	OUT COM	9	SYNC
5	-V OUT	10	IN COM

Figure 20 – Flanged, Seam Seal Package and Pinout

PACKAGE PIN DESCRIPTION

Pin	Function	Description
1	28V IN	Positive Input Voltage Connection
2	INHIBIT	Logic Low = Disabled Output. Connecting the inhibit pin to input common causes converter shutdown. Logic High = Enabled Output. Unconnected or open collector TTL.
3	+V OUT	Positive Output Voltage Connection
4	OUT COM	Output Common Connection
5	-V OUT	Negative Output Voltage Connection
6	CASE	Case Connection
7	CASE	Case Connection
8	CASE	Case Connection
9	SYNC	Synchronization Signal
10	IN COM	Input Common Connection

ENVIRONMENTAL SCREENING (100% Tested Per MIL-STD-883 as referenced to MIL-PRF-38534)

Screening	MIL-STD-883	Standard (No Suffix)	Extended /ES	HB /HB	Class H /H	Class K /K
Non-Destructive Bond Pull	Method 2023	•	•	•	•	•
Internal Visual	Method 2017, 2032 Internal Procedure	•	•	•	•	•
Temperature Cycling	Method 1010, Condition C Method 1010, -55°C to 125°C		•	•	•	•
Constant Acceleration	Method 2001, 3000g, Y1 Direction Method 2001, 500g, Y1 Direction		•	•	•	•
PIND	Method 2020, Condition A ²					•
Pre Burn-In Electrical	100% at 25°C					•
Burn-In	Method 1015, 320 hours at +125°C Method 1015, 160 hours at +125°C 96 hours at +125°C 24 hours at +125°C	•	•	•	•	•
Final Electrical	MIL-PRF-38534, Group A ¹ 100% at 25°C	•	•	•	•	•
Hermeticity	Method 1014, Fine Leak, Condition A Method 1014, Gross Leak, Condition C Dip (1 x 10 ⁻³)	•	•	•	•	•
Radiography	Method 2012 ³					•
External Visual	Method 2009	•	•	•	•	•

- Notes:
1. 100% R&R testing at -55°C, +25°C, and +125°C with all test data included in product shipment.
 2. PIND test Certificate of Compliance included in product shipment.
 3. Radiographic test Certificate of Compliance and film(s) included in product shipment.

ORDERING INFORMATION

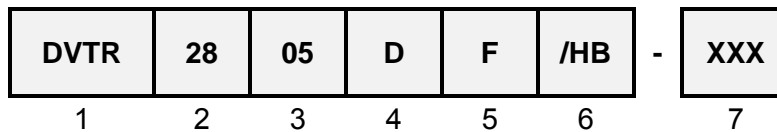

(1) Product Series	(2) Nominal Input Voltage		(3) Output Voltage		(4) Number of Outputs	
DVTR	28	28 Volts	05 08 12 15 18	± 5 Volts ± 8 Volts ± 12 Volts ± 15 Volts ± 18 Volts	D	Dual

(5) Package Option		(6) Screening Code ^{1,2}		(7) Additional Screening Code
None F	Non-Flanged Flanged	None /ES /HB /H /K	Standard Extended HB Class H Class K	Contact Sales

- Notes:
1. Contact the VPT Inc. Sales Department for availability of Class H (/H) or Class K (/K) qualified products.
 2. VPT Inc. reserves the right to ship higher screened or SMD products to meet lower screened orders at our sole discretion unless specifically forbidden by customer contract.

Please contact your sales representative or the VPT Inc. Sales Department for more information concerning additional environmental screening and testing, different input voltage, output voltage, power requirement, source inspection, and/or special element evaluation for space or other higher quality applications.

SMD (STANDARD MICROCIRCUIT DRAWING) NUMBERS

Standard Microcircuit Drawing (SMD)	DVTR2800D Series Similar Part Number
5962-1122501HXC 5962-1122501HYC	DVTR2805D/H DVTR2805DF/H
5962-1122502HXC 5962-1122502HYC	DVTR2812D/H DVTR2812DF/H
5962-1122503HXC 5962-1122503HYC	DVTR2815D/H DVTR2815DF/H

Do not use the DVTR2800D Series similar part number for SMD product acquisition. It is listed for reference only. For exact specifications for the SMD product, refer to the SMD drawing. SMD's can be downloaded from the DLA Land and Maritime (Previously known as DSCC) website at <http://www.dsccl.dla.mil/programs/smcr/>. The SMD number listed above is for MIL-PRF-38534 Class H screening, standard gold plated lead finish, and no RHA (Radiation Hardness Assurance) level. Please reference the SMD for other screening levels, lead finishes, and radiation levels. All SMD products are marked with a "Q" on the cover as specified by the QML certification mark requirement of MIL-PRF-38534.

CONTACT INFORMATION

To request a quotation or place an order please contact your sales representative or the VPT Inc. Sales Department at:

Phone: (425) 353-3010
Fax: (425) 353-4030
E-mail: vptsales@vpt-inc.com

All information contained in this datasheet is believed to be accurate, however, no responsibility is assumed for possible errors or omissions. The products or specifications contained herein are subject to change without notice.