



DVPL0510S Series

HIGH RELIABILITY HYBRID DC-DC CONVERTERS

DESCRIPTION

The DVPL series of high reliability DC-DC converters is operable over the full military (-55 °C to +125 °C) temperature range with no power derating. Operating at a nominal fixed frequency of 300 kHz, these regulated, non-isolated converters are optimized for low voltage point of load applications with high efficiency synchronous rectification, fast transient response, and power sequencing capability.

These converters are designed and manufactured in a facility qualified to ISO9001 and certified to MIL-PRF-38534 and MIL-STD-883.

This product may incorporate one or more of the following U.S. patents:

- 5,784,266
- 5,790,389
- 5,963,438
- 5,999,433
- 6,005,780
- 6,084,792
- 6,118,673

FEATURES

- High Reliability
- Operates From 5V Input
- Adjustable Output Voltage, 0.8V to 3.4V
- Up to 10 Amps or 33W Output
- High Efficiency, Up to 96%
- High Power Density: >100 W/in³
- Output Voltage Sequencing
- Output Voltage Tracking
- Operation Into a Pre-Biased Output
- Output Inhibit Control
- Low Output Noise
- NO Use of Optoisolators
- Over Current and Short Circuit Protection
- Precision Projection Welded Hermetic Package
- Meets MIL-STD-461C and MIL-STD-461D EMC Requirements When Used With VPT DC-DC Converters and EMI filters
- Additional Environmental Screening Available
- MIL-PRF-38534 Element Evaluated Components

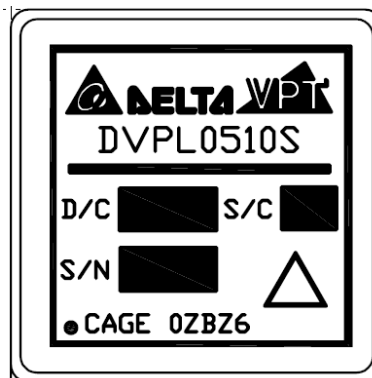

Figure 1 – DVPL0510S DC-DC Converter
(Exact marking may differ from that shown)

SPECIFICATIONS ($T_{CASE} = -55^{\circ}\text{C}$ to $+125^{\circ}\text{C}$, $V_{IN} = +5\text{V} \pm 5\%$, Full Load, Unless Otherwise Specified)

ABSOLUTE MAXIMUM RATINGS

Input Voltage (Continuous)	5.5 V_{DC}	Junction Temperature Rise to Case	+15°C
Input Voltage (Transient, 1 second)	5.8 V_{DC}	Storage Temperature	-65°C to +150°C
Output Power ¹	33 Watts	Lead Solder Temperature (10 seconds)	270°C
Power Dissipation (Full Load, $T_{CASE} = +125^{\circ}\text{C}$)	3.3 Watt	Weight (Maximum)	16 Grams
ESD Rating per MIL-PRF-38534	2		

Parameter	Conditions	DVPL0510S			Units	
		Min	Typ	Max		
STATIC						
INPUT Voltage ⁴	V_{IN}	Continuous	4.5	-	5.5	V
		Transient	-	-	5.8	V
Current		Inhibited	-	-	3	mA
		No Load	-	-	80	mA
Inhibit Pin Input ⁴			0	-	1.5	V
Inhibit Pin Open Circuit Voltage ⁴			-	-	V_{in}	V
UVLO Turn On ^{4,6}			-	2.2	-	V
UVLO Turn Off ⁴			-	2.0	-	V
OUTPUT Voltage	V_{OUT}	$T_{CASE} = 25^{\circ}\text{C}$	-1.5	V_{out}	+1.5	% V_{out}
		$T_{CASE} = -55^{\circ}\text{C}$ to $+125^{\circ}\text{C}$	-2.5	V_{out}	+2.5	% V_{out}
Power ^{3,1}		$V_{OUT} = 3.3\text{V}$	0	-	33	W
Current ³	V_{OUT}		0	-	10	A
Ripple Voltage	V_{OUT}	Full Load, 20Hz to 10MHz	-	40	80	mV _{p-p}
Load Regulation	V_{OUT}	No Load to Full Load	-	25	60	mV
EFFICIENCY		$V_{out} = 3.3\text{V}$	91	95	-	%
FAULT POWER DISSIPATION		Short Circuit	-	-	3	W
CAPACITIVE LOAD ⁴			-	-	5000	μF
SWITCHING FREQUENCY			240	300	350	kHz
CASE ISOLATION		500 V_{DC}	100	-	-	M Ω
MTBF (MIL-HDBK-217F)		AIF @ $T_c = 55^{\circ}\text{C}$	-	562	-	kHrs
DYNAMIC						
Load Step Output Transient ⁵	V_{OUT}	Half Load to Full Load	-	150	300	mV
Load Step Recovery ^{2,5}			-	70	160	μSec
Turn On Delay	V_{OUT}	$V_{IN} = 0\text{V}$ to 5V	-	-	8	mSec
Turn On Overshoot			-	-	40	mV _{PK}
VOLTAGE TRACKING						
Tracking Accuracy ⁴		Power-up	-	100	300	mV
		Power-down	-	200	400	mV
Slew Rate ⁴		At track pin	0.1	-	2	V/msec
Tracking Delay ⁴		From V_{in} to tracking voltage applied	10	-	-	ms

Notes: 1. Dependant on output voltage. 2. Time for output voltage to settle within 1% or 20mV of its nominal value, whichever is greater. 3. Derate linearly to 0 at 135°C. 4. Verified by qualification testing. 5. With 100 μF capacitor from V_{in} to Ground. 6. V_{out} not necessarily in regulation.

BLOCK DIAGRAM

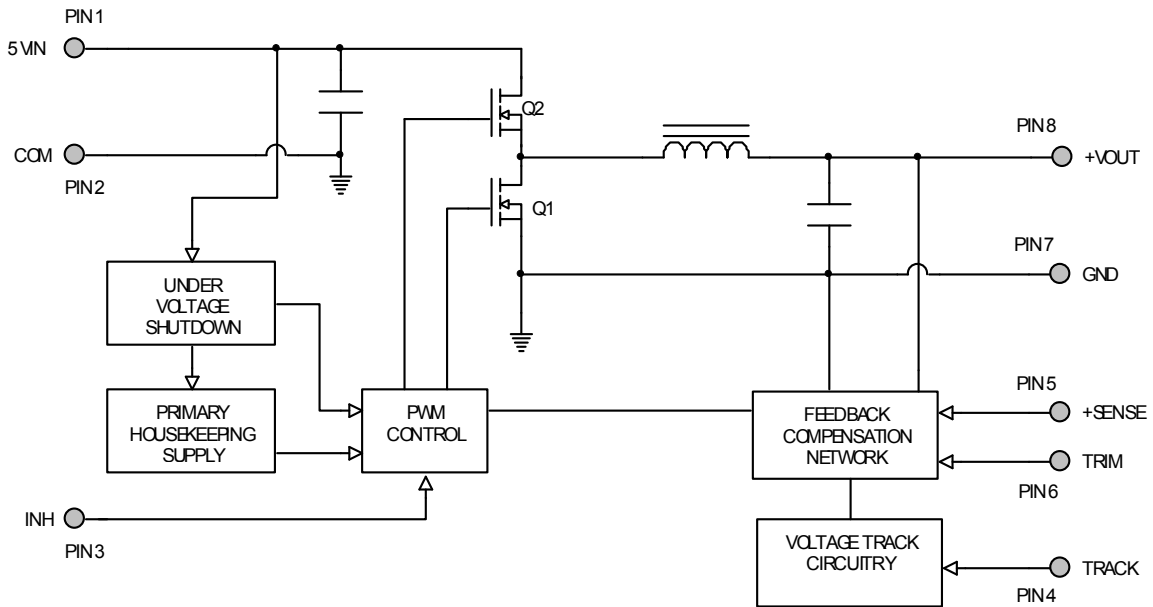

Figure 2

CONNECTION DIAGRAM

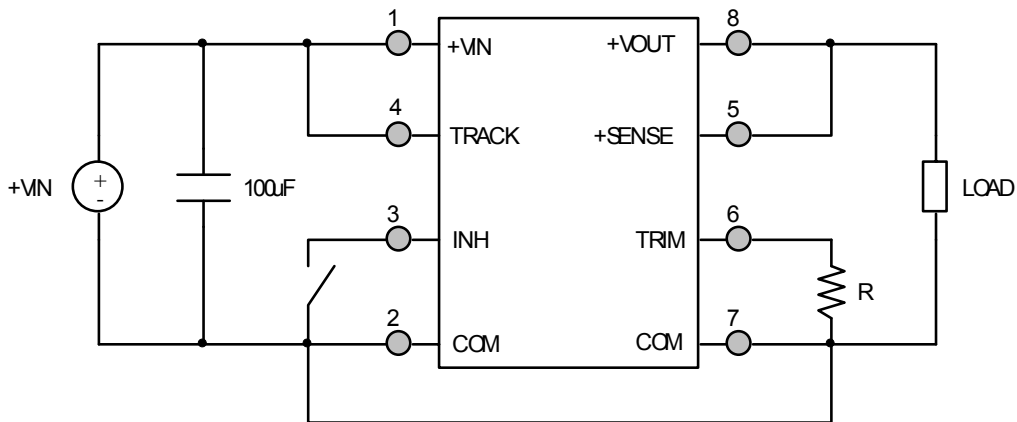

Figure 3

(Shown with recommended 100µF input capacitor)

INTERNAL CONNECTION DIAGRAMS

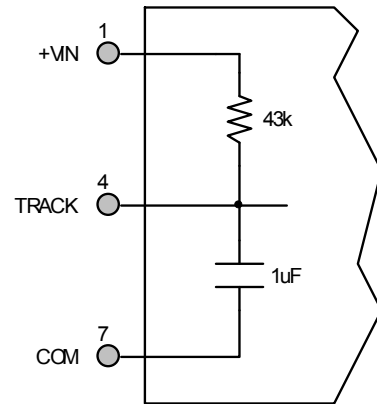
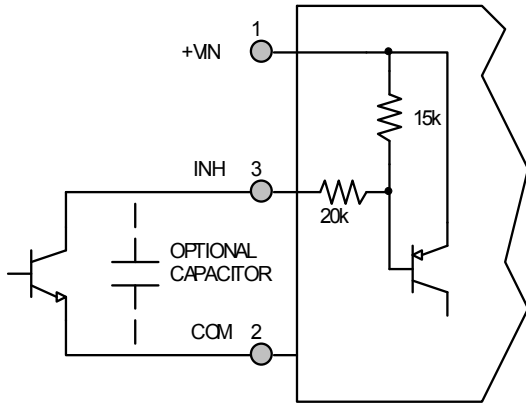

Figure 6 – Internal Inhibit Circuit and Recommended Drive
(Shown with optional capacitor for turn-on delay)

Figure 7 – Internal Track Circuit

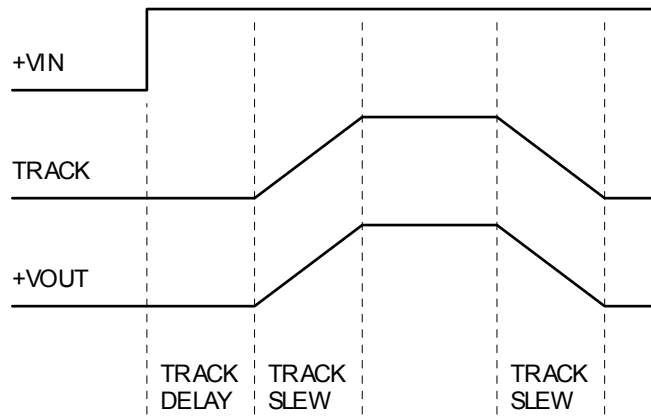
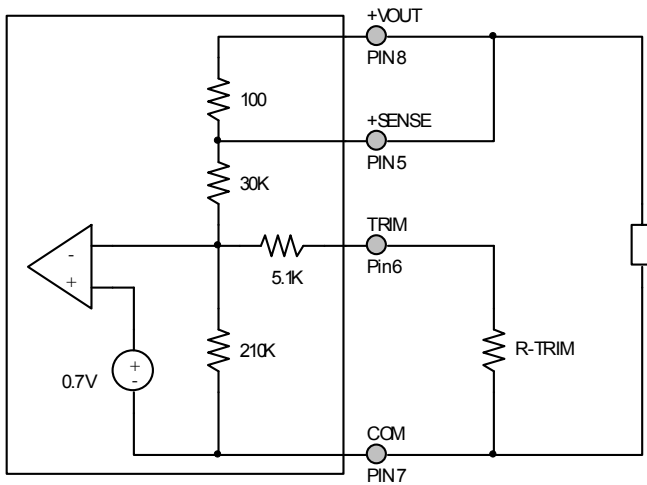

Figure 8 – Track timing relations

OUTPUT VOLTAGE TRIM



The output voltage is set with an external resistor connected from the TRIM pin to the GND pin 7. This resistor must have a tolerance of 1% or less to achieve an accurate output voltage.

The default output voltage with the TRIM pin left open is 0.80V.

DVPL0510S	
+V _{OUT} (V)	R _{TRIM} (Ω)
0.8	-
0.9	205k
1.0	99.9k
1.2	47.4k
1.5	24.9k
1.8	15.9k
1.9	14k
2.0	12.4k
2.5	7.25k
2.8	5.40k
3.0	4.44k
3.3	3.30k
3.4	2.98k

$$V_o = \frac{168R_{TRIM} + 5.267 * 10^6}{210R_{TRIM} + 1.071 * 10^6}$$

$$R_{TRIM} = \frac{5.267 * 10^6 - 1.071 * 10^6 * V_o}{210 * V_o - 168}$$

Figure 9 – Output Voltage Trim

EFFICIENCY PERFORMANCE CURVES ($T_{CASE} = 25^{\circ}C$, Full Load, Unless Otherwise Specified)

——— $V_{OUT} = 3.3V$	- - - - - $V_{OUT} = 2.5V$	- · - · - · $V_{OUT} = 1.5V$	- · - · - · $V_{OUT} = 0.8V$
----------------------	----------------------------	------------------------------	------------------------------

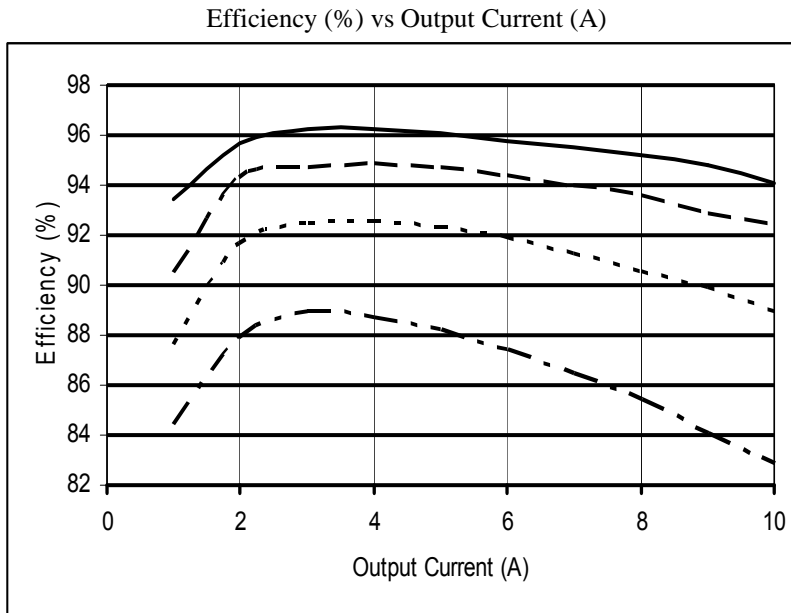

Figure 10 – DVPL0510S $V_{in}=5.0V$
Efficiency (%) vs. Output Current (A)

EMI PERFORMANCE CURVES ($T_{CASE} = 25^{\circ}C$, Full Load, Unless Otherwise Specified)

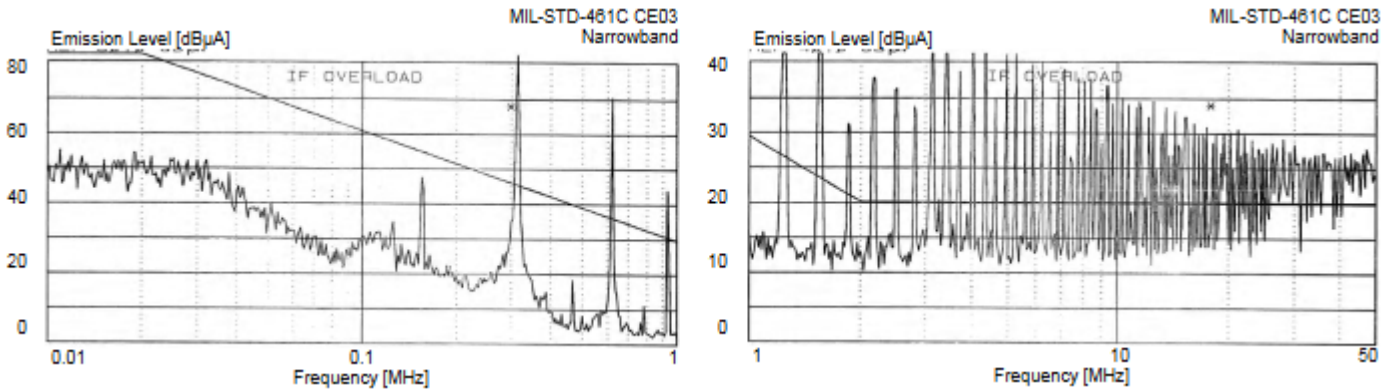

Figure 11 – 5V input line, DVPL, $C_{IN}=100\mu F$

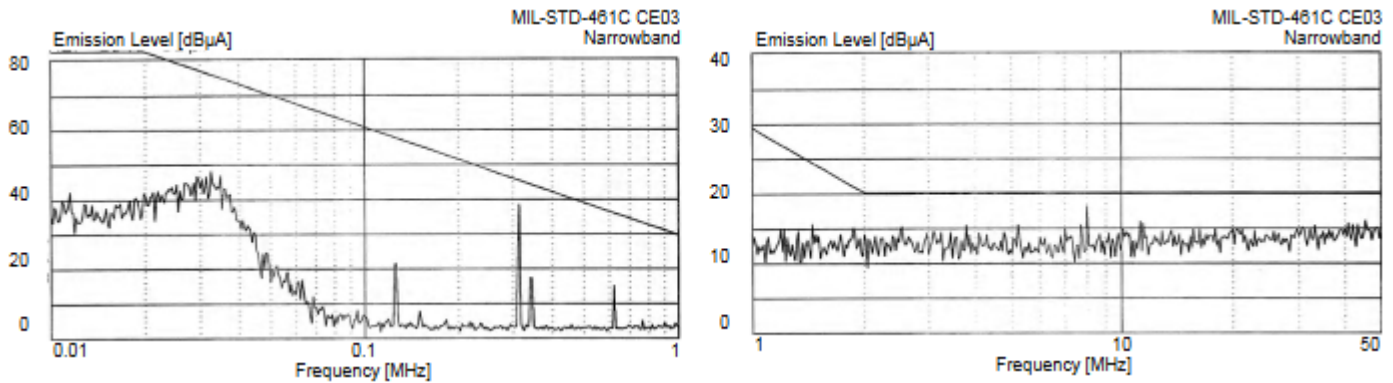

Figure 12 – 5V input line, DVMD and DVPL, $C_{IN}=100\mu F$

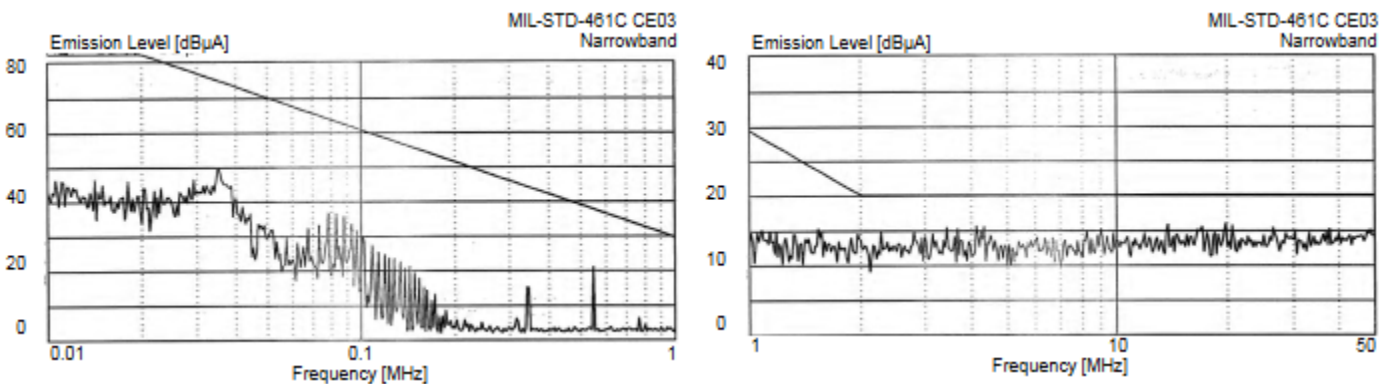
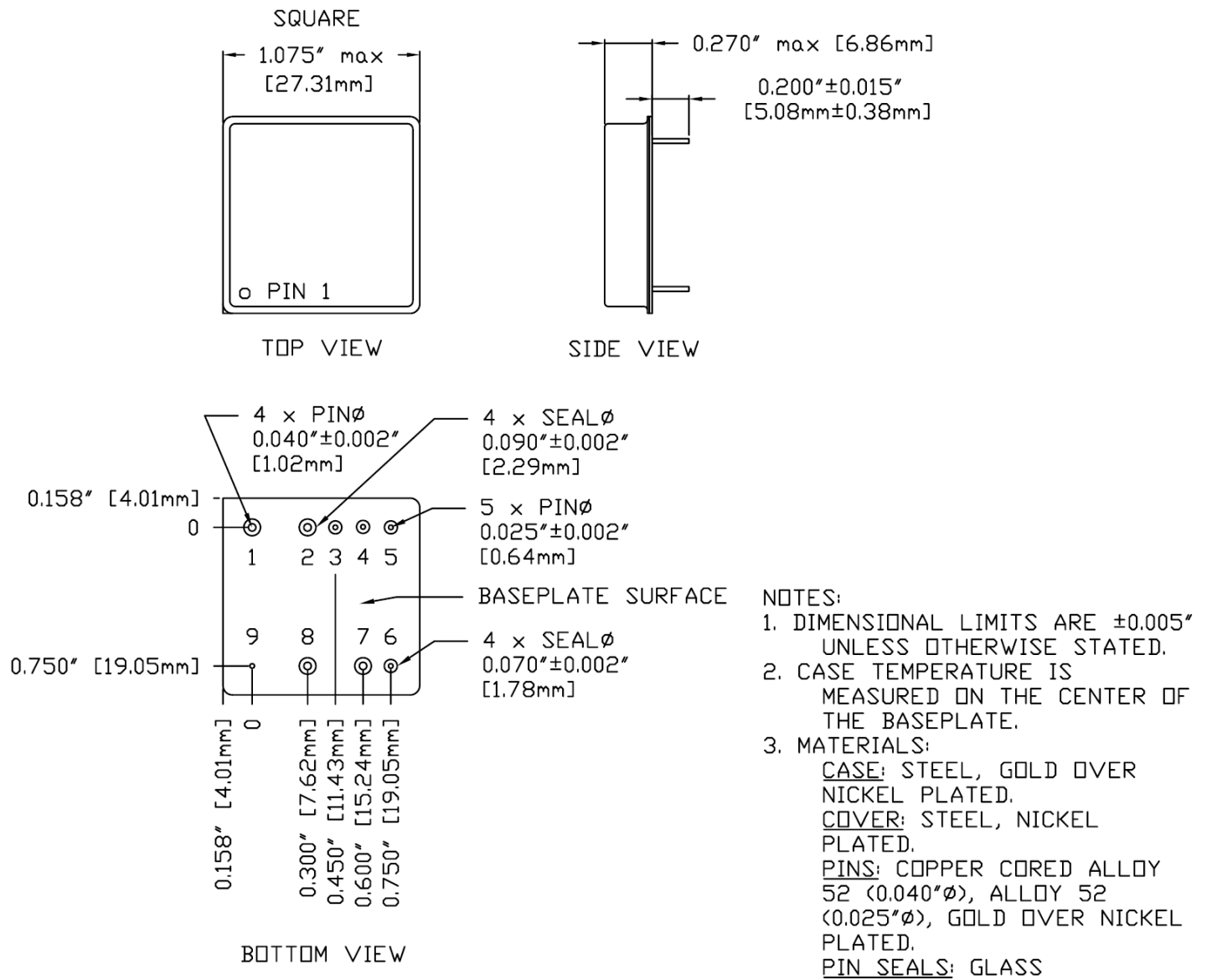

Figure 13- 28V input line, DVME, DVFL and DVPL, $C_{IN}=100\mu F$

PACKAGE SPECIFICATIONS



PIN	FUNCTION	PIN	FUNCTION	PIN	FUNCTION
1	+V IN	4	TRACK	7	COM
2	COM	5	+SENSE	8	+V OUT
3	INHIBIT	6	TRIM	9	CASE

Figure 14 – Package and Pinout

PACKAGE PIN DESCRIPTION

Pin	Function	Description
1	+VIN	Positive Input Voltage Connection
2	COM	Common Return Connection, Input Side
3	INHIBIT	Logic Low = Disabled Output. Connecting the inhibit pin to common causes converter shutdown. Logic High (open collector or open drain) = Enabled Output. Leave open if not used.
4	TRACK	The output voltage will follow this pin. Used for output voltage sequencing or tracking. If not used, the Track pin should be connected to Vin.
5	+SENSE	Positive Sense
6	TRIM	Trim pin sets output voltage with a resistor to pin 7
7	COM	Common Return Connection, Output Side
8	+VOUT	Positive Output Voltage Connection
9	CASE	Case Connection

ENVIRONMENTAL SCREENING (100% Tested Per MIL-STD-883 as referenced to MIL-PRF-38534)

Screening	MIL-STD-883	Standard (No Suffix)	Extended /ES	HB /HB	Class H /H	Class K /K
Non-Destructive Bond Pull	Method 2023	•	•	•	•	•
Internal Visual	Method 2017, 2032 Internal Procedure	•	•	•	•	•
Temperature Cycling	Method 1010, Condition C Method 1010, -55°C to 125°C		•	•	•	•
Constant Acceleration	Method 2001, 3000g, Y1 Direction Method 2001, 500g, Y1 Direction		•	•	•	•
PIND	Method 2020, Condition A ²					•
Pre Burn-In Electrical	100% at 25°C					•
Burn-In	Method 1015, 320 hours at +125°C Method 1015, 160 hours at +125°C 96 hours at +125°C 24 hours at +125°C	•	•	•	•	•
Final Electrical	MIL-PRF-38534, Group A ¹ 100% at 25°C	•	•	•	•	•
Hermeticity	Method 1014, Fine Leak, Condition A Method 1014, Gross Leak, Condition C Dip (1×10^{-3})	•	•	•	•	•
Radiography	Method 2012 ³					•
External Visual	Method 2009	•	•	•	•	•

- Notes:
1. 100% R&R testing at -55°C, +25°C, and +125°C with all test data included in product shipment.
 2. PIND test Certificate of Compliance included in product shipment.
 3. Radiographic test Certificate of Compliance and film(s) included in product shipment.

ORDERING INFORMATION

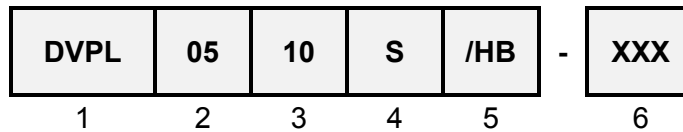

(1)

(2)

(3)

(4)

Product Series	Nominal Input Voltage		Output Current		Number of Outputs	
DVPL	05	5 Volts	10	10 Amps	S	Single

(5)

(6)

Screening Code ^{1,2}		Additional Screening Code
None /ES /HB /H /K	Standard Extended HB Class H Class K	Contact Sales

- Notes:
1. Contact the VPT Inc. Sales Department for availability of Class H (/H) or Class K (/K) qualified products.
 2. VPT Inc. reserves the right to ship higher screened or SMD products to meet lower screened orders at our sole discretion unless specifically forbidden by customer contract.

Please contact your sales representative or the VPT Inc. Sales Department for more information concerning additional environmental screening and testing, different input voltage, output voltage, power requirement, source inspection, and/or special element evaluation for space or other higher quality applications.

SMD (STANDARD MICROCIRCUIT DRAWING) NUMBERS

Standard Microcircuit Drawing (SMD)	DVPL0510S Series Similar Part Number
*T.B.D.	DVPL0510S/H

Do not use the DVPL0510S Series similar part number for SMD product acquisition. It is listed for reference only. For exact specifications for the SMD product, refer to the SMD drawing. SMD's can be downloaded from the DSCC website at <http://www.dsccl.dla.mil/programs/smcr/>. The SMD number listed above is for MIL-PRF-38534 Class H screening, standard gold plated lead finish, and no RHA (Radiation Hardness Assurance) level. Please reference the SMD for other screening levels, lead finishes, and radiation levels. All SMD products are marked with a "Q" on the cover as specified by the QML certification mark requirement of MIL-PRF-38534.

CONTACT INFORMATION

To request a quotation or place orders please contact your sales representative or the VPT Inc. Sales Department at:

Phone: (425) 353-3010
Fax: (425) 353-4030
E-mail: vptsales@vpt-inc.com

All information contained in this datasheet is believed to be accurate, however, no responsibility is assumed for possible errors or omissions. The products or specifications contained herein are subject to change without notice.