



SVHF2800S Series

HIGH RELIABILITY HYBRID RADIATION TOLERANT DC-DC CONVERTERS

DESCRIPTION

The SVHF series of high reliability DC-DC converters is operable over the full military (-55 °C to +125 °C) temperature range with no power derating. Paramount to the SVHF series is a magnetic feedback circuit that is radiation immune. Operating at a nominal fixed frequency of 450 kHz, these regulated, isolated units utilize well controlled undervoltage lockout circuitry to eliminate slow start-up problems. The SVHF series has been characterized and tested for TID (Total Ionizing Dose) at HDR (High Dose Rate) and LDR (Low Dose Rate – ELDRS) per VPT's RHA plan. The SVHF series has also been characterized for SEE (Single Event Effects). VPT's certified radiation program per MIL-PRF-38534, Appendix G is currently under review by DSCC. Please contact DSCC at 614-692-0585 for details. This characterization and testing is performed at the critical semiconductor component piece-part level (RLAT) from traceable semiconductor lots as well as on the SVHF series hybrid converter level produced from the same traceable semiconductor lots evaluated during RLAT.

These converters are designed and manufactured in a facility qualified to ISO9001 and certified to MIL-PRF-38534 Class H and Class K and MIL-STD-883.

This product may incorporate one or more of the following U.S. patents:

5,784,266 5,790,389 5,963,438 5,999,433
 6,005,780 6,084,792 6,118,673

FEATURES

- High Reliability
- Very Low Output Noise
- Wide Input Voltage Range: 15 to 50 Volts per MIL-STD-704
- Up to 20 Watts Output Power
- Radiation Immune Magnetic Feedback Circuit
- NO Use of Optoisolators
- Undervoltage Lockout
- Indefinite Short Circuit Protection
- Current Limit Protection
- High Input Transient Voltage: 80 Volts for 1 sec per MIL-STD-704A
- Precision Projection Welded Hermetic Package
- High Power Density: > 37 W/in³
- Custom Modified Versions May Be Available
- Additional Environmental Screening Available
- Meets MIL-STD-461C and MIL-STD-461D EMC Requirements When Used With a DVMH28 EMI Filter
- Flanged and Non-flanged Versions Available.
- MIL-PRF-38534 Element Evaluated Components Utilized
- Characterized and assured to 30krads(Si), per VPT's RHA plan specified per MIL-PRF-38534, Appendix G, Level P with 2X margin. After radiation exposure, converter testing is performed at 25°C per standard datasheet limits.
- Characterized to 44 MeV-cm²/mg with minor transients only; no dropouts, shutdowns, latch up or burn out.
- Critical semiconductor component piece-parts and assured converter products tested at an HDR of 80 rads(Si)/sec and an LDR of 8 mrads(Si)/sec.



Figure 1 – SVHF2800S / SVHF2800SF DC-DC Converter (Exact marking may differ from that shown)

SPECIFICATIONS ($T_{CASE} = -55^{\circ}\text{C}$ to $+125^{\circ}\text{C}$, $V_{IN} = +28\text{V} \pm 5\%$, Full Load, Unless Otherwise Specified)

ABSOLUTE MAXIMUM RATINGS

Input Voltage (Continuous)	50 V_{DC}	Junction Temperature Rise to Case	+12°C
Input Voltage (Transient, 1 second)	80 Volts	Storage Temperature	-65°C to +150°C
Output Power ¹	20 Watts	Lead Solder Temperature (10 seconds)	270°C
Power Dissipation (Full Load, $T_{CASE} = +125^{\circ}\text{C}$)	6 Watts	Weight (Maximum) (Un-Flanged / Flanged)	(24 / 27) Grams

Parameter	Conditions	SVHF283R3S			SVHF2805S			Units
		Min	Typ	Max	Min	Typ	Max	
STATIC								
INPUT Voltage ⁴	Continuous	15	28	50	15	28	50	V
	Transient, 1 sec	-	-	80	-	-	80	V
Current	Inhibited	-	-	6	-	-	6	mA
	No Load	-	40	65	-	40	65	mA
Ripple Current	Full Load, 20Hz to 10MHz	-	-	80	-	-	80	mA _{p-p}
Inhibit Pin Input ⁴		0	-	1.5	0	-	1.5	V
Inhibit Pin Open Circuit Voltage ⁴		9	11	13	9	11	13	V
UVLO Turn On		12	-	14.8	12	-	14.8	V
UVLO Turn Off ⁴		11	-	14.5	11	-	14.5	V
OUTPUT Voltage	V_{OUT} $T_{CASE} = 25^{\circ}\text{C}$	3.267	3.30	3.333	4.95	5.00	5.05	V
	V_{OUT} $T_{CASE} = -55^{\circ}\text{C}$ to $+125^{\circ}\text{C}$	3.25	3.30	3.35	4.925	5.00	5.075	V
Power ³		0	-	10	0	-	15	W
Current ³	V_{OUT}	0	-	3	0	-	3	A
Ripple Voltage	V_{OUT} Full Load, 20Hz to 10MHz	-	-	40	-	-	40	mV _{p-p}
Line Regulation	V_{OUT} $V_{IN} = 15\text{V}$ to 50V	-	-	20	-	-	20	mV
Load Regulation	V_{OUT} No Load to Full Load	-	-	50	-	-	50	mV
EFFICIENCY		65	-	-	72	-	-	%
LOAD FAULT POWER DISSIPATION	Overload ⁴	-	-	8	-	-	8	W
	Short Circuit	-	-	8	-	-	8	W
CAPACITIVE LOAD ⁴		-	-	1000	-	-	1000	μF
SWITCHING FREQUENCY		350	450	500	350	450	500	kHz
ISOLATION	500 V_{DC}	100	-	-	100	-	-	M Ω
MTBF (MIL-HDBK-217F)	SF @ $T_C = 55^{\circ}\text{C}$	-	776	-	-	776	-	kHrs
DYNAMIC								
Load Step Output Transient	V_{OUT} Half Load to Full Load	-	-	400	-	-	600	mV _{PK}
Load Step Recovery ²		-	-	500	-	-	600	μSec
Line Step Output Transient ⁴	V_{OUT} $V_{IN} = 16\text{V}$ to 40V	-	400	700	-	400	800	mV _{PK}
Line Step Recovery ^{2, 4}		-	300	500	-	300	700	μSec
Turn On Delay	V_{OUT} $V_{IN} = 0\text{V}$ to 28V	-	10	20	-	10	20	mSec
Turn On Overshoot		-	0	15	-	0	25	mV _{PK}

Notes: 1. Dependant on output voltage. 2. Time for output voltage to settle within 1% of its nominal value.
3. Derate linearly to 0 at 135°C. 4. Verified by qualification testing.

SPECIFICATIONS ($T_{CASE} = -55^{\circ}C$ to $+125^{\circ}C$, $V_{IN} = +28V \pm 5\%$, Full Load, Unless Otherwise Specified)

ABSOLUTE MAXIMUM RATINGS

Input Voltage (Continuous)	50 V_{DC}	Junction Temperature Rise to Case	+12°C
Input Voltage (Transient, 1 second)	80 Volts	Storage Temperature	-65°C to +150°C
Output Power ¹	20 Watts	Lead Solder Temperature (10 seconds)	270°C
Power Dissipation (Full Load, $T_{CASE} = +125^{\circ}C$)	6 Watts	Weight (Maximum) (Un-Flanged / Flanged)	(24 / 27) Grams

Parameter	Conditions	SVHF2812S			SVHF2815S			Units
		Min	Typ	Max	Min	Typ	Max	
STATIC								
INPUT Voltage ⁴	Continuous	15	28	50	15	28	50	V
	Transient, 1 sec	-	-	80	-	-	80	V
Current	Inhibited	-	-	6	-	-	6	mA
	No Load	-	40	65	-	40	65	mA
Ripple Current	Full Load, 20Hz to 10MHz	-	-	80	-	-	80	mA _{p-p}
Inhibit Pin Input ⁴		0	-	1.5	0	-	1.5	V
Inhibit Pin Open Circuit Voltage ⁴		9	11	13	9	11	13	V
UVLO Turn On		12	-	14.8	12	-	14.8	V
UVLO Turn Off ⁴		11	-	14.5	11	-	14.5	V
OUTPUT Voltage	V_{OUT} $T_{CASE} = 25^{\circ}C$	11.88	12.00	12.12	14.85	15.00	15.15	V
	V_{OUT} $T_{CASE} = -55^{\circ}C$ to $+125^{\circ}C$	11.82	12.00	12.18	14.775	15.00	15.225	V
Power ³		0	-	20	0	-	20	W
Current ³	V_{OUT}	0	-	1.67	0	-	1.34	A
Ripple Voltage	V_{OUT} Full Load, 20Hz to 10MHz	-	-	40	-	-	40	mV _{p-p}
Line Regulation	V_{OUT} $V_{IN} = 15V$ to $50V$	-	-	20	-	-	20	mV
Load Regulation	V_{OUT} No Load to Full Load	-	-	50	-	-	50	mV
EFFICIENCY		77	-	-	78	-	-	%
LOAD FAULT POWER DISSIPATION	Overload ⁴	-	-	8	-	-	8	W
	Short Circuit	-	-	8	-	-	8	W
CAPACITIVE LOAD ⁴		-	-	500	-	-	500	μF
SWITCHING FREQUENCY		350	450	500	350	450	500	kHz
ISOLATION	500 V_{DC}	100	-	-	100	-	-	M Ω
MTBF (MIL-HDBK-217F)	SF @ $T_C = 55^{\circ}C$	-	776	-	-	776	-	kHrs
DYNAMIC								
Load Step Output Transient	V_{OUT} Half Load to Full Load	-	-	500	-	-	500	mV _{PK}
Load Step Recovery ²		-	-	500	-	-	500	μSec
Line Step Output Transient ⁴	V_{OUT} $V_{IN} = 16V$ to $40V$	-	500	900	-	500	900	mV _{PK}
Line Step Recovery ^{2, 4}		-	300	500	-	300	500	μSec
Turn On Delay	V_{OUT} $V_{IN} = 0V$ to $28V$	-	10	20	-	10	20	mSec
Turn On Overshoot		-	0	50	-	0	50	mV _{PK}

Notes: 1. Dependant on output voltage. 2. Time for output voltage to settle within 1% of its nominal value.
3. Derate linearly to 0 at 135°C. 4. Verified by qualification testing.

SPECIFICATIONS ($T_{CASE} = -55^{\circ}\text{C}$ to $+125^{\circ}\text{C}$, $V_{IN} = +28\text{V} \pm 5\%$, Full Load, Unless Otherwise Specified)

ABSOLUTE MAXIMUM RATINGS

Input Voltage (Continuous)	50 V_{DC}	Junction Temperature Rise to Case	+12°C
Input Voltage (Transient, 1 second)	80 Volts	Storage Temperature	-65°C to +150°C
Output Power ¹	20 Watts	Lead Solder Temperature (10 seconds)	270°C
Power Dissipation (Full Load, $T_{CASE} = +125^{\circ}\text{C}$)	6 Watts	Weight (Maximum) (Un-Flanged / Flanged)	(24 / 27) Grams

Parameter	Conditions	SVHF285R2S			SVHF281R9S			Units
		Min	Typ	Max	Min	Typ	Max	
STATIC								
INPUT Voltage ⁴	Continuous	15	28	50	15	28	50	V
	Transient, 1 sec	-	-	80	-	-	80	V
Current	Inhibited	-	-	6	-	-	6	mA
	No Load	-	40	65	-	40	65	mA
Ripple Current	Full Load, 20Hz to 10MHz	-	-	80	-	-	80	mA _{p-p}
Inhibit Pin Input ⁴		0	-	1.5	0	-	1.5	V
Inhibit Pin Open Circuit Voltage ⁴		9	11	13	9	11	13	V
UVLO Turn On		12	-	14.8	12	-	14.8	V
UVLO Turn Off ⁴		11	-	14.5	11	-	14.5	V
OUTPUT Voltage	V_{OUT} $T_{CASE} = 25^{\circ}\text{C}$	5.148	5.20	5.252	1.87	1.90	1.93	V
	V_{OUT} $T_{CASE} = -55^{\circ}\text{C}$ to $+125^{\circ}\text{C}$	5.122	5.20	5.278	1.86	1.90	1.94	V
Power ³		0	-	15	0	-	8	W
Current ³	V_{OUT}	0	-	3	0	-	4	A
Ripple Voltage	V_{OUT} Full Load, 20Hz to 10MHz	-	-	40	-	-	40	mV _{p-p}
Line Regulation	V_{OUT} $V_{IN} = 15\text{V}$ to 50V	-	-	20	-	-	20	mV
Load Regulation	V_{OUT} No Load to Full Load	-	-	50	-	-	65	mV
EFFICIENCY		72	-	-	59	-	-	%
LOAD FAULT POWER DISSIPATION	Overload ⁴	-	-	8	-	-	8	W
	Short Circuit	-	-	8	-	-	8	W
CAPACITIVE LOAD ⁴		-	-	1000	-	-	1000	μF
SWITCHING FREQUENCY		350	450	500	350	450	500	kHz
ISOLATION	500 V_{DC}	100	-	-	100	-	-	M Ω
MTBF (MIL-HDBK-217F)	SF @ $T_C = 55^{\circ}\text{C}$	-	776	-	-	776	-	kHrs
DYNAMIC								
Load Step Output Transient	V_{OUT} Half Load to Full Load	-	-	600	-	-	250	mV _{PK}
Load Step Recovery ²		-	-	600	-	-	600	μSec
Line Step Output Transient ⁴	V_{OUT} $V_{IN} = 16\text{V}$ to 40V	-	400	800	-	100	400	mV _{PK}
Line Step Recovery ^{2, 4}		-	300	700	-	200	700	μSec
Turn On Delay	V_{OUT} $V_{IN} = 0\text{V}$ to 28V	-	10	20	-	10	20	mSec
Turn On Overshoot		-	0	25	-	0	15	mV _{PK}

Notes: 1. Dependant on output voltage. 2. Time for output voltage to settle within 1% of its nominal value.
3. Derate linearly to 0 at 135°C. 4. Verified by qualification testing.

SPECIFICATIONS ($T_{CASE} = -55^{\circ}C$ to $+125^{\circ}C$, $V_{IN} = +28V \pm 5\%$, Full Load, Unless Otherwise Specified)

ABSOLUTE MAXIMUM RATINGS

Input Voltage (Continuous)	50 V_{DC}	Junction Temperature Rise to Case	+12°C
Input Voltage (Transient, 1 second)	80 Volts	Storage Temperature	-65°C to +150°C
Output Power ¹	20 Watts	Lead Solder Temperature (10 seconds)	270°C
Power Dissipation (Full Load, $T_{CASE} = +125^{\circ}C$)	6 Watts	Weight (Maximum) (Un-Flanged / Flanged)	(24 / 27) Grams

Parameter	Conditions	SVHF2828S			Units
		Min	Typ	Max	
STATIC					
INPUT Voltage ⁴	Continuous	15	28	50	V
	Transient, 1 sec	-	-	80	V
Current	Inhibited	-	-	6	mA
	No Load	-	45	65	mA
Ripple Current	Full Load, 20Hz to 10MHz	-	-	100	mA _{p-p}
Inhibit Pin Input ⁴		0	-	1.5	V
Inhibit Pin Open Circuit Voltage ⁴		9	11	13	V
UVLO Turn On		12	-	14.8	V
UVLO Turn Off ⁴		11	-	14.5	V
OUTPUT Voltage	V_{OUT} $T_{CASE} = 25^{\circ}C$	27.70	28.00	28.30	V
	V_{OUT} $T_{CASE} = -55^{\circ}C$ to $+125^{\circ}C$	27.25	28.00	28.75	V
Power ³		0	-	20	W
Current ³	V_{OUT}	0	-	0.714	A
Ripple Voltage	V_{OUT} Full Load, 20Hz to 10MHz	-	-	120	mV _{p-p}
Line Regulation	V_{OUT} $V_{IN} = 15V$ to $50V$	-	-	150	mV
Load Regulation	V_{OUT} No Load to Full Load	-	-	150	mV
EFFICIENCY		79	-	-	%
LOAD FAULT POWER DISSIPATION	Overload ⁴	-	-	8	W
	Short Circuit	-	-	8	W
CAPACITIVE LOAD ⁴		-	-	500	μF
SWITCHING FREQUENCY		350	450	500	kHz
ISOLATION	500 V_{DC}	100	-	-	M Ω
MTBF (MIL-HDBK-217F)	SF @ $T_C = 55^{\circ}C$	-	776	-	kHrs
DYNAMIC					
Load Step Output Transient	V_{OUT} Half Load to Full Load	-	-	800	mV _{PK}
Load Step Recovery ²		-	-	400	μSec
Line Step Output Transient ⁴	V_{OUT} $V_{IN} = 16V$ to $40V$	-	900	1200	mV _{PK}
Line Step Recovery ^{2, 4}		-	400	700	μSec
Turn On Delay	V_{OUT} $V_{IN} = 0V$ to $28V$	-	10	20	mSec
Turn On Overshoot		-	0	50	mV _{PK}

Notes: 1. Dependant on output voltage. 2. Time for output voltage to settle within 1% of its nominal value.
 3. Derate linearly to 0 at 135°C. 4. Verified by qualification testing.

BLOCK DIAGRAM

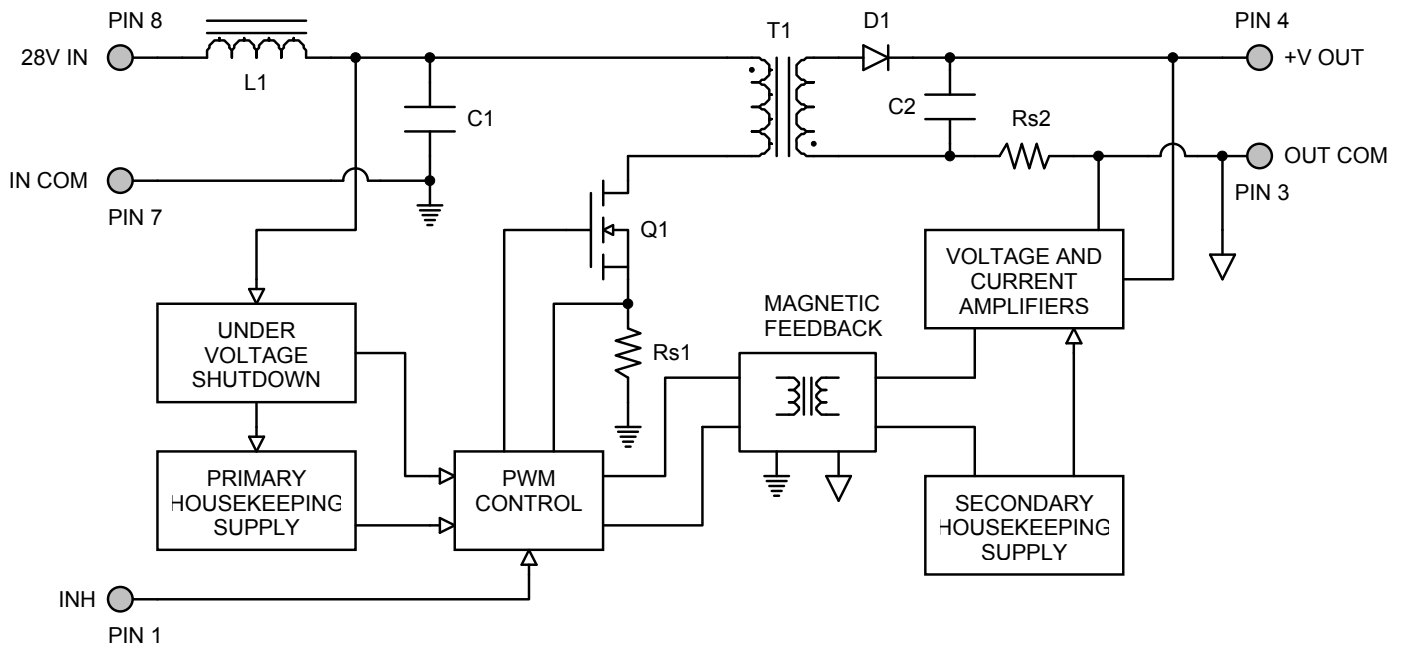

Note: Not applicable to SVHF2828S.

Figure 2

CONNECTION DIAGRAM

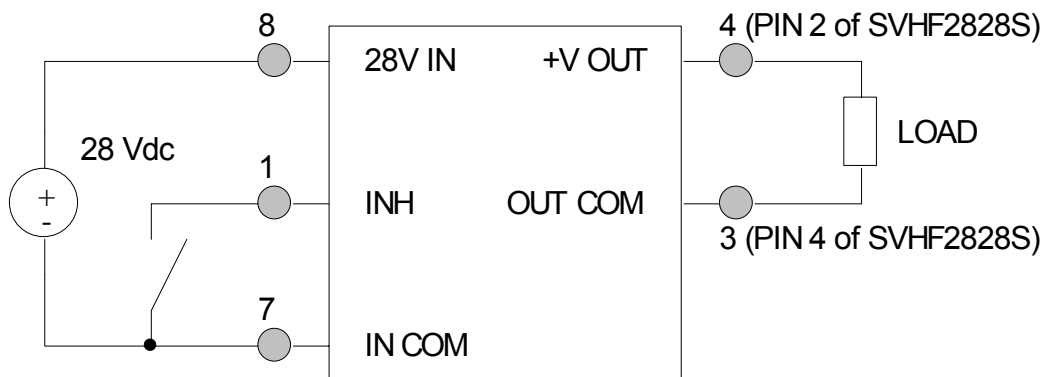

Figure 3

INHIBIT DRIVE CONNECTION DIAGRAMS

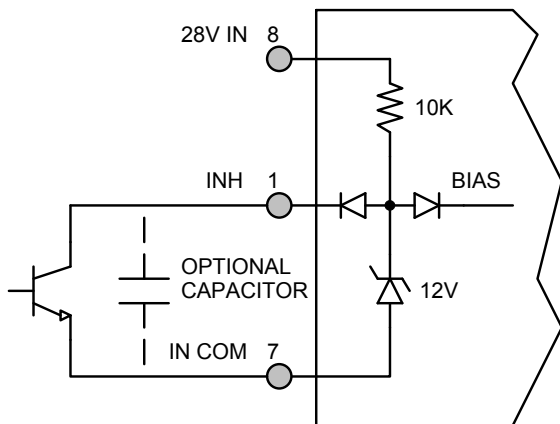

Figure 4 – Internal Inhibit Circuit and Recommended Drive
(Shown with optional capacitor for turn-on delay)

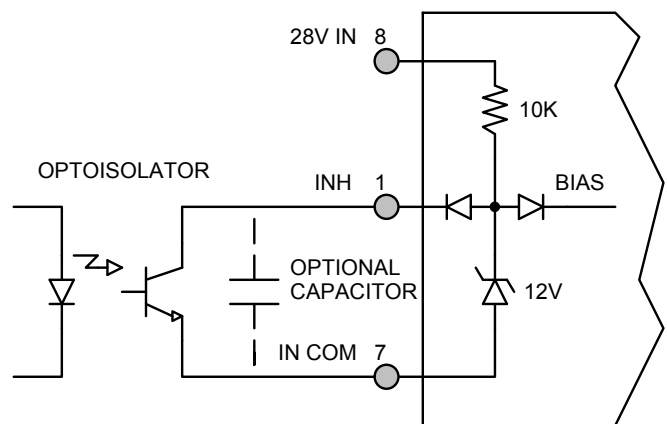

Figure 5 – Isolated Inhibit Drive
(Shown with optional capacitor for turn-on delay)

EMI FILTER HOOKUP DIAGRAM

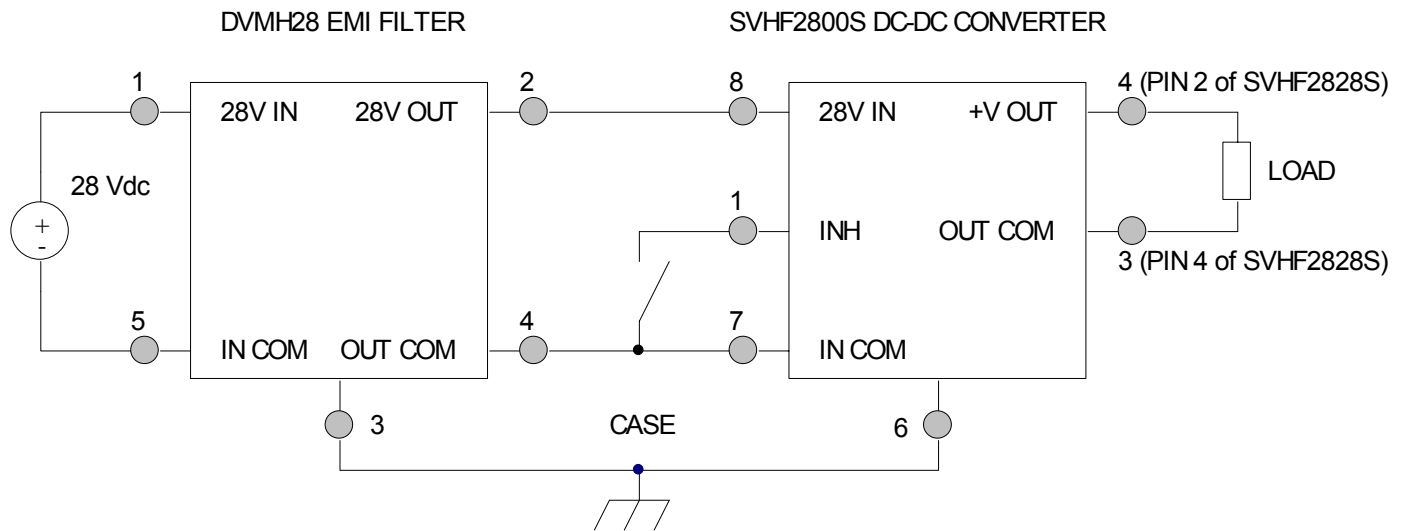

Figure 6 – Converter with EMI Filter

RHA TEST CIRCUIT DIAGRAM

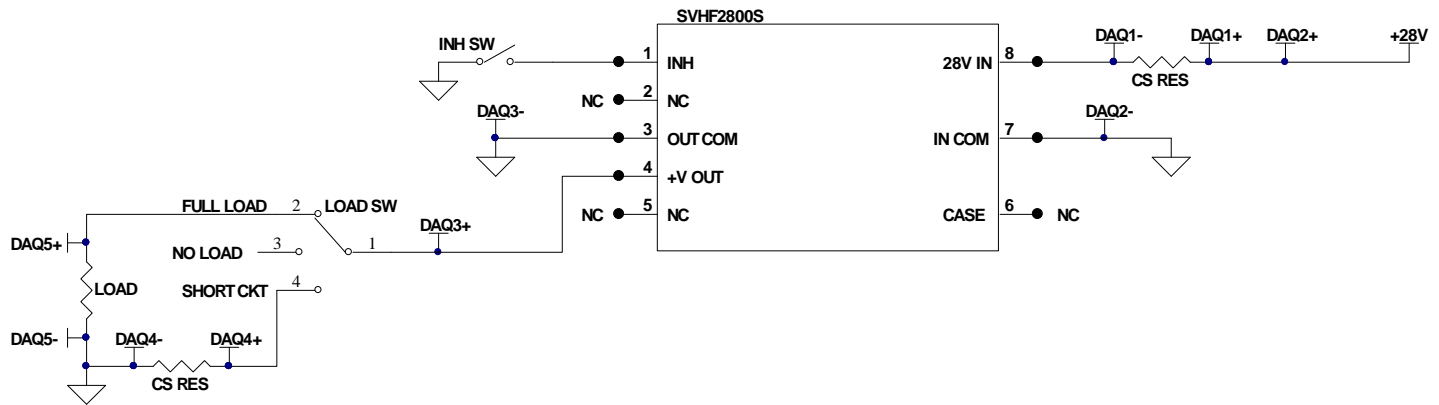

Figure 7

FREQUENCY OF RHA TESTING

Every initial wafer lot of critical semiconductor components has been characterized and tested at HDR as well as at LDR to determine if there is ELDRS sensitivity. If a specific component type is determined to have ELDRS sensitivity, all future wafer lots of that specific component will be tested at LDR. If no ELDRS sensitivity is shown in the initial wafer lot testing, future wafer lots of those specific components will not be tested at LDR. All future critical semiconductor component wafer lots are tested at HDR. If the components test to the same level (within 15% of the previous 99/90 RLAT level) or better as the wafer lot used to characterize the converter family, the converter family is not re-characterized. If the components test to a worse level, one of the following actions is performed (depending on the test level passed):

1. Component lot is not used in VPT RHA assured product.
2. Component lot is used if WCA (Worst Case Analysis) performed on the new lot against the original characterization WCA determines the component level characterized will not negatively impact the assured product characterization level.
3. The assured product is re-characterized using the new component lot.

EFFICIENCY PERFORMANCE CURVES ($T_{CASE} = 25^{\circ}C$, Full Load, Unless Otherwise Specified)

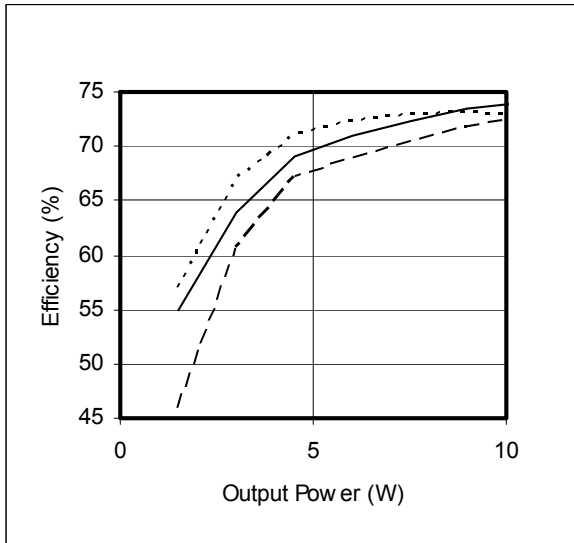

Figure 8 – SVHF283R3S
Efficiency (%) vs. Output Power (W)

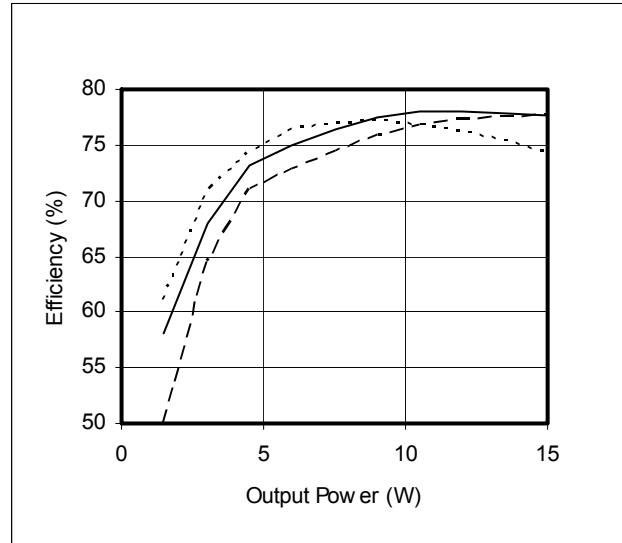

Figure 9 – SVHF2805S / SVHF285R2S
Efficiency (%) vs. Output Power (W)

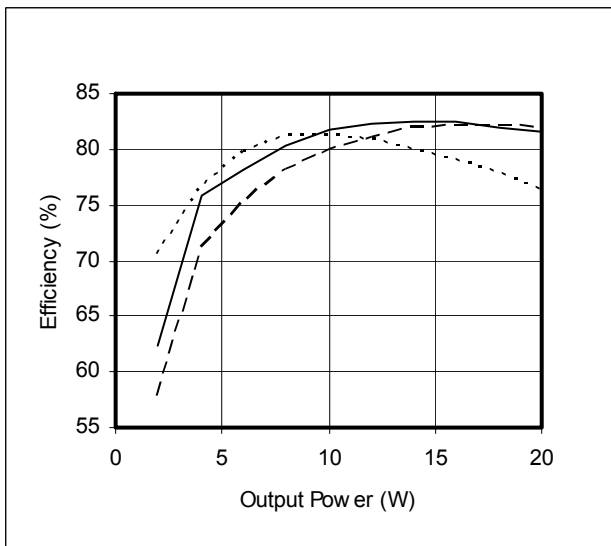

Figure 10 – SVHF2812S
Efficiency (%) vs. Output Power (W)

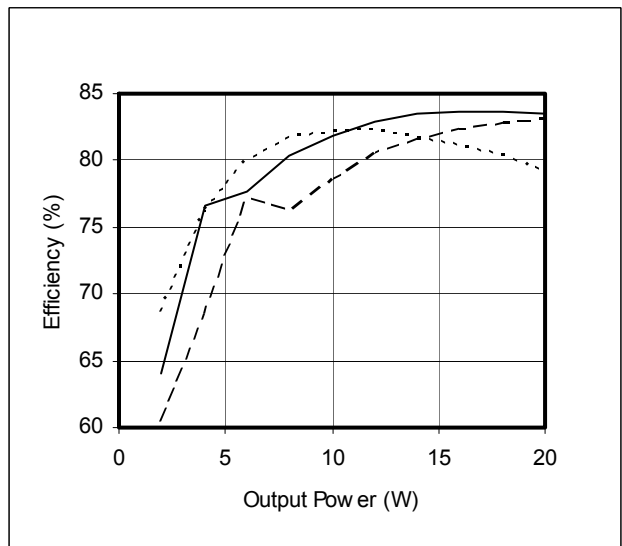

Figure 11 – SVHF2815S
Efficiency (%) vs. Output Power (W)

EFFICIENCY PERFORMANCE CURVES ($T_{CASE} = 25^{\circ}C$, Full Load, Unless Otherwise Specified)

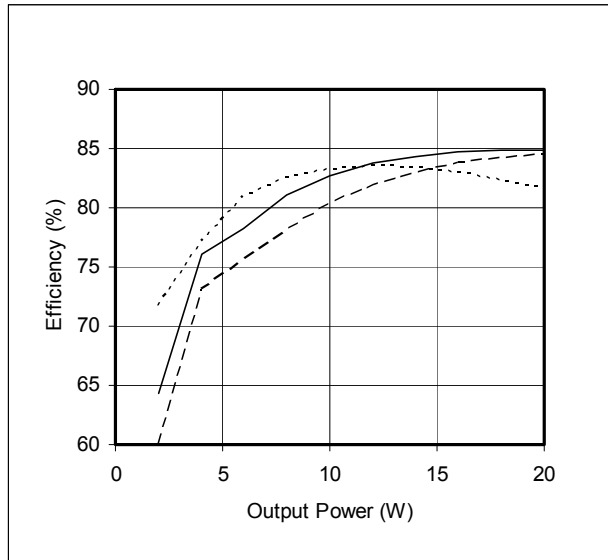

Figure 12 – SVHF2828S
Efficiency (%) vs. Output Power (W)

EMI PERFORMANCE CURVES

($T_{CASE} = 25^{\circ}C$, $V_{IN} = +28V \pm 5\%$, Full Load, Unless Otherwise Specified)

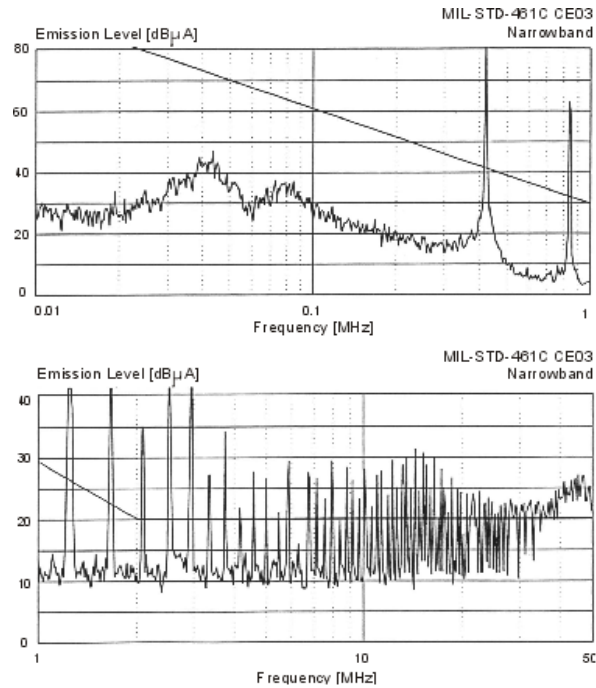

Figure 13 – SVHF2800S without EMI Filter

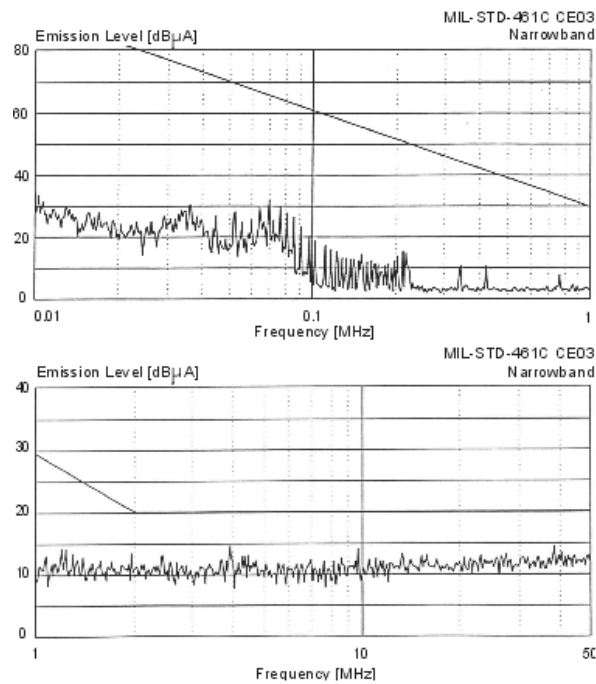
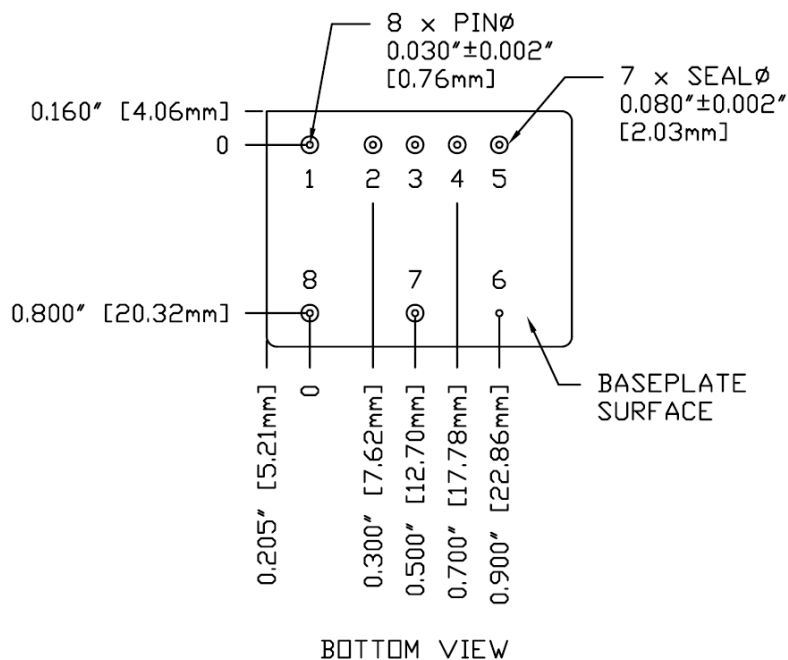
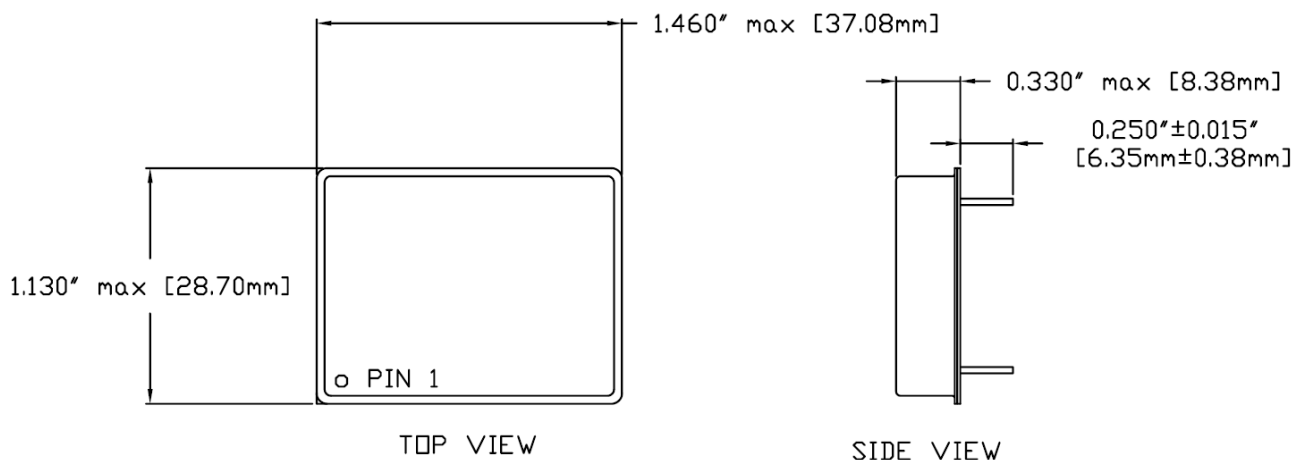

Figure 14 – SVHF2800S with EMI Filter

PACKAGE SPECIFICATIONS (NON-FLANGED)



- NOTES:
1. DIMENSIONAL LIMITS ARE $\pm 0.005"$ UNLESS OTHERWISE STATED.
 2. CASE TEMPERATURE IS MEASURED ON THE CENTER OF THE BASEPLATE.
 3. MATERIALS:
CASE: STEEL, GOLD OVER NICKEL PLATED.
COVER: STEEL, NICKEL PLATED.
PINS: ALLOY 52, GOLD OVER NICKEL PLATED.
PIN SEALS: GLASS

All Outputs Except SVHF2828S			
PIN	FUNCTION	PIN	FUNCTION
1	INHIBIT	5	N/C
2	N/C	6	CASE
3	OUT COM	7	IN COM
4	+V OUT	8	28V IN

SVHF2828S			
PIN	FUNCTION	PIN	FUNCTION
1	INHIBIT	5	N/C
2	+V OUT	6	CASE
3	*	7	IN COM
4	OUT COM	8	28V IN

*Pin 3 of SVHF2828S provides a +14V output referenced to OUT COM.

Figure 15 – Non-Flanged Package and Pinout

PACKAGE SPECIFICATIONS (FLANGED)

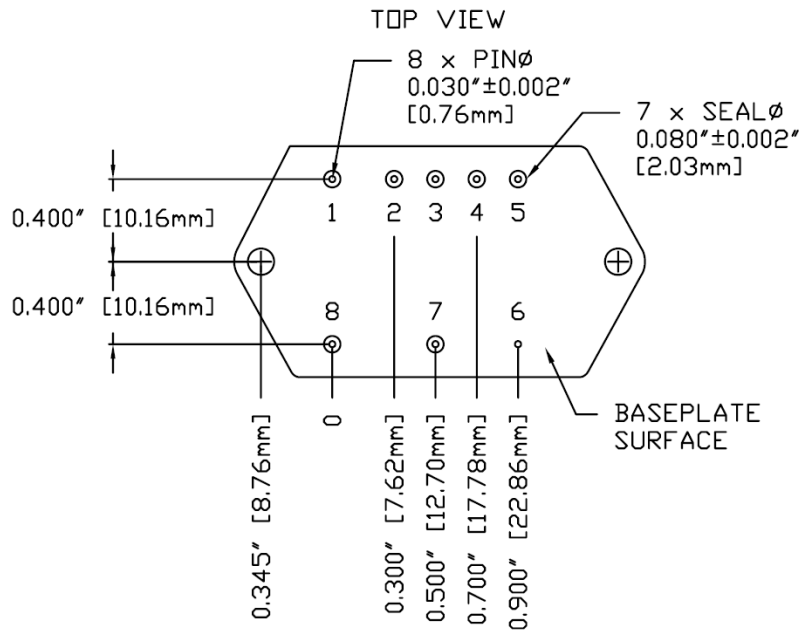
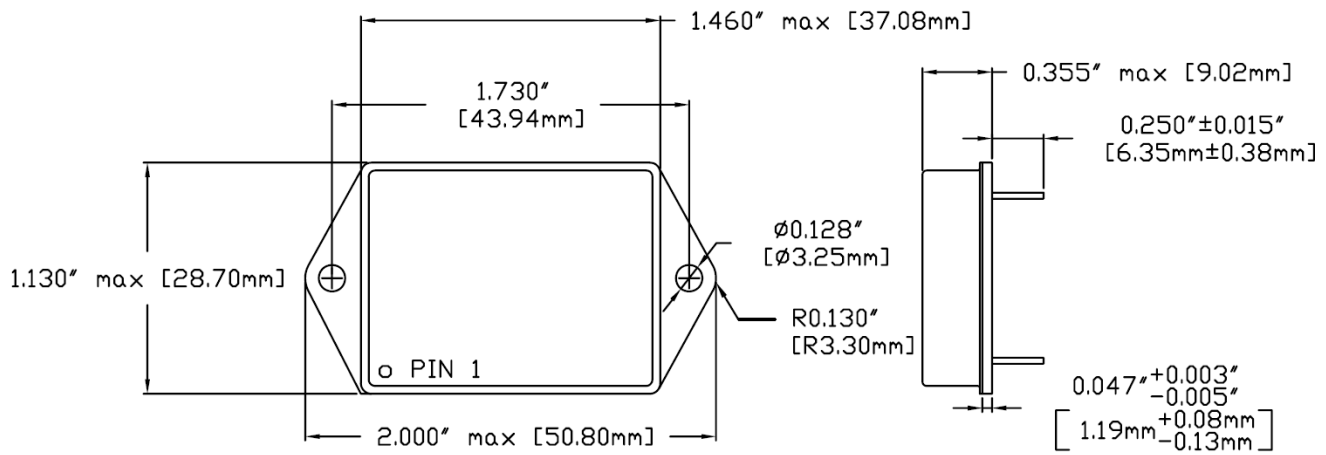

- NOTES:
1. DIMENSIONAL LIMITS ARE $\pm 0.005"$ UNLESS OTHERWISE STATED.
 2. CASE TEMPERATURE IS MEASURED ON THE CENTER OF THE BASEPLATE.
 3. MOUNTING HOLES ARE NOT THREADED. RECOMMENDED FASTENER IS #4-40 SCREW.
 4. MATERIALS:
 CASE: STEEL, GOLD OVER NICKEL PLATED.
 COVER: STEEL, NICKEL PLATED.
 PINS: ALLOY 52, GOLD OVER NICKEL PLATED.
 PIN SEALS: GLASS

All Outputs Except SVHF2828S			
PIN	FUNCTION	PIN	FUNCTION
1	INHIBIT	5	N/C
2	N/C	6	CASE
3	OUT COM	7	IN COM
4	+V OUT	8	28V IN

SVHF2828S			
PIN	FUNCTION	PIN	FUNCTION
1	INHIBIT	5	N/C
2	+V OUT	6	CASE
3	*	7	IN COM
4	OUT COM	8	28V IN

*Pin 3 of SVHF2828S provides a +14V output referenced to OUT COM.

Figure 16 – Flanged Package and Pinout

PACKAGE PIN DESCRIPTION

All Outputs Except SVHF2828S:

Pin	Function	Description
1	INHIBIT	Logic Low = Disabled Output. Connecting the inhibit pin to input common causes converter shutdown. Logic High = Enabled Output. Unconnected or open collector TTL.
2	N/C	No Connection
3	OUT COM	Output Common Connection
4	+V OUT	Positive Output Voltage Connection
5	N/C	No Connection
6	CASE	Case Connection
7	IN COM	Input Common Connection
8	28V IN	Positive Input Voltage Connection

SVHF2828S:

Pin	Function	Description
1	INHIBIT	Logic Low = Disabled Output. Connecting the inhibit pin to input common causes converter shutdown. Logic High = Enabled Output. Unconnected or open collector TTL.
2	+V OUT	Positive Output Voltage Connection
3	*	Provides +14V output referenced to OUT COM.
4	OUT COM	Output Common Connection
5	N/C	No Connection
6	CASE	Case Connection
7	IN COM	Input Common Connection
8	28V IN	Positive Input Voltage Connection

ENVIRONMENTAL SCREENING (100% Tested Per MIL-STD-883 as referenced to MIL-PRF-38534)

Screening	MIL-STD-883	Class H+ /H+	Engineering Model ⁵ /EM
Non-Destructive Bond Pull	Method 2023	•	•
Internal Visual	Method 2017, 2032 Internal Procedure	•	•
Temperature Cycling	Method 1010, Condition C	•	
Constant Acceleration	Method 2001, 3000g, Y1 Direction	•	
PIND	Method 2020, Condition A ²	•	
Burn-In	Method 1015, 160 hours at +125°C 24 Hours at +125°C	•	•
Final Electrical	MIL-PRF-38534, Group A ¹ 100% at 25°C	•	•
Hermeticity	Method 1014, Fine Leak, Condition A Method 1014, Gross Leak, Condition C Dip (1 x 10 ⁻³)	• •	•
External Visual	Method 2009	•	•

- Notes:
- 100% R&R testing at -55°C, +25°C, and +125°C with all test data included in product shipment.
 - PIND test Certificate of Compliance included in product shipment. This is an additional screening test not required per MIL-PRF-38534, Class H.
 - Non-Destructive bond pull per Method 2023 performed. This is an additional screening test not required per MIL-PRF-38534, Class H.
 - Please contact your sales representative or the VPT Inc. Sales Department for more information concerning additional environmental screening and testing options desired.
 - Engineering models utilize only the standard screening specified and are not considered compliant for flight use.

ORDERING INFORMATION

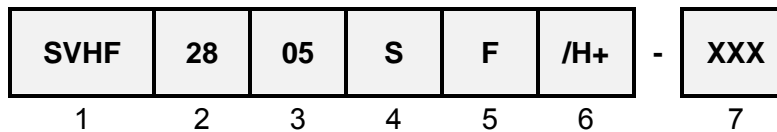

(1) Product Series	(2) Nominal Input Voltage		(3) Output Voltage		(4) Number of Outputs	
SVHF	28	28 Volts	1R9 3R3 05 5R2 12 15 28	1.9 Volts 3.3 Volts 5 Volts 5.2 Volts 12 Volts 15 Volts 28 Volts	S	Single

(5) Package Option		(6) Screening Code		(7) Additional Screening Code
None F	Non-Flanged Flanged	/H+ /EM	Class H+ Engineering Model	Contact Sales

Note: Engineering models utilize only the standard screening specified and are not considered compliant for flight use. These models are intended for low volume engineering characterization. The customer must place the following statement on each line item of their purchase order(s) for /EM units when ordering engineering models:

“(Customer Name) acknowledges that the /EM unit listed in this line item is not permitted for flight use and will be used for Engineering characterization only.”

Please contact your sales representative or the VPT Inc. Sales Department for more information concerning additional environmental screening and testing, different input voltage, output voltage, power requirement, source inspection, and/or special element evaluation for space or other higher quality applications.

SMD (STANDARD MICROCIRCUIT DRAWING) NUMBERS

Standard Microcircuit Drawing (SMD)	SVHF2800S Series Similar Part Number
*T.B.D.	SVHF281R9S/H+ SVHF281R9SF/H+
*T.B.D.	SVHF283R3S/H+ SVHF283R3SF/H+
*T.B.D.	SVHF2805S/H+ SVHF2805SF/H+
*T.B.D.	SVHF285R2S/H+ SVHF285R2SF/H+
*T.B.D.	SVHF2812S/H+ SVHF2812SF/H+
*T.B.D.	SVHF2815S/H+ SVHF2815SF/H+
*T.B.D.	SVHF2828S/H+ SVHF2828SF/H+

VPT's certified radiation program per MIL-PRF-38534, Appendix G is currently under review by DSCC. Please contact DSCC at 614-692-0585 for details. Standard MIL-PRF-38534 Class H SMD's are available. Please see the standard product DVHF2800S datasheet for details.

Do not use the SVHF2800S Series similar part number for SMD product acquisition. It is listed for reference only. For exact specifications for the SMD product, refer to the SMD drawing. SMD's can be downloaded from the DSCC website at <http://www.dsccl.dla.mil/programs/smcr/>. The SMD number listed above is for MIL-PRF-38534 Class H screening + PIND Testing, standard gold plated lead finish, and "P" RHA (Radiation Hardness Assurance) level. Please reference the SMD for other screening levels, lead finishes, and radiation levels. All SMD products are marked with a "Q" on the cover as specified by the QML certification mark requirement of MIL-PRF-38534.

CONTACT INFORMATION

To request a quotation or place orders please contact your sales representative or the VPT Inc. Sales Department at:

Phone: (425) 353-3010
Fax: (425) 353-4030
E-mail: vptsales@vpt-inc.com

All information contained in this datasheet is believed to be accurate, however, no responsibility is assumed for possible errors or omissions. The products or specifications contained herein are subject to change without notice.