



SVFL2800D Series

HIGH RELIABILITY HYBRID RADIATION TOLERANT DC-DC CONVERTERS

DESCRIPTION

The SVFL series of high reliability DC-DC converters is operable over the full military (-55 °C to +125 °C) temperature range with no power derating. Paramount to the SVFL series is a magnetic feedback circuit that is radiation immune. Operating at a nominal fixed frequency of 500 kHz, these regulated, isolated units utilize well controlled undervoltage lockout circuitry to eliminate slow start-up problems. The current sharing function allows a maximum of five units to be connected in parallel to boost the total output power to 5 times. The output voltage is trimmable up to +10% or down -20%. The SVFL series has been characterized and tested for TID (Total Ionizing Dose) at HDR (High Dose Rate) and LDR (Low Dose Rate – ELDRS) per VPT’s RHA plan. The SVFL series has also been characterized for SEE (Single Event Effects). VPT’s certified radiation program per MIL-PRF-38534, Appendix G is currently under review by DSCC. Please contact DSCC at 614-692-0585 for details. This characterization and testing is performed at the critical semiconductor component piece-part level (RLAT) from traceable semiconductor lots as well as on the SVFL series hybrid converter level produced from the same traceable semiconductor lots evaluated during RLAT.

These converters are designed and manufactured in a facility qualified to ISO9001 and certified to MIL-PRF-38534 Class H and Class K and MIL-STD-883.

This product may incorporate one or more of the following U.S. patents:

5,784,266 5,790,389 5,963,438 5,999,433
 6,005,780 6,084,792 6,118,673

FEATURES

- High Reliability
- Parallel Up to 5 Units With Current Sharing
- Output Voltage Trim Up +10% or Down -20%
- Wide Input Voltage Range: 16 to 40 Volts per MIL-STD-704
- Up to 120 Watts Output Power
- Radiation Immune Magnetic Feedback Circuit
- NO Use of Optoisolators
- Undervoltage Lockout
- Indefinite Short Circuit Protection
- Current Limit Protection
- High Input Transient Voltage: 50 Volts for 1 sec per MIL-STD-704A
- Precision Seam Welded Hermetic Package
- High Power Density: > 80 W/in³
- Custom Modified Versions May Be Available
- Additional Environmental Screening Available
- Meets MIL-STD-461C and MIL-STD-461D EMC Requirements When Used With a DVME28 EMI Filter
- MIL-PRF-38534 Element Evaluated Components Utilized
- Characterized and assured to 30krads(Si), per VPT’s RHA plan specified per MIL-PRF-38534, Appendix G, Level P with 2X margin. After radiation exposure, converter testing is performed at 25°C per standard datasheet limits.
- Characterized to 44 MeV-cm²/mg with minor transients only; no dropouts, shutdowns, latch up or burn out.
- Critical semiconductor component piece-parts and assured converter products tested at an HDR of 90 rads(Si)/sec and an LDR of 8 mrads(Si)/sec.

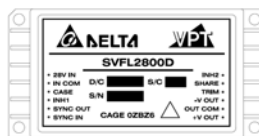

Figure 1 – SVFL2800D DC-DC Converter (Exact marking may differ from that shown)

SPECIFICATIONS ($T_{CASE} = -55^{\circ}\text{C}$ to $+125^{\circ}\text{C}$, $V_{IN} = +28\text{V} \pm 5\%$, Full Load⁵, Unless Otherwise Specified)

ABSOLUTE MAXIMUM RATINGS

Input Voltage (Continuous)	40 V _{DC}	Junction Temperature Rise to Case	+15°C
Input Voltage (Transient, 1 second)	50 Volts	Storage Temperature	-65°C to +150°C
Output Power ¹	120 Watts	Lead Solder Temperature (10 seconds)	270°C
Power Dissipation (Full Load, $T_{CASE} = +125^{\circ}\text{C}$)	40 Watts	Weight (Maximum) (No Pin Extensions)	88 Grams

Parameter	Conditions	SVFL2805D			SVFL2812D			Units	
		Min	Typ	Max	Min	Typ	Max		
STATIC									
INPUT Voltage ⁴	Continuous	16	28	40	16	28	40	V	
	Transient, 1 sec	-	-	50	-	-	50	V	
Current	Inhibited 1	-	-	3	-	-	3	mA	
	Inhibited 2	-	-	70	-	-	70	mA	
	No Load	-	-	160	-	-	160	mA	
Ripple Current	Full Load ⁵ , 20Hz to 10MHz	-	-	80	-	-	80	mA _{p-p}	
INH1 Pin Input ⁴		0	-	1.5	0	-	1.5	V	
INH2 Pin Input ⁴		0	-	1	0	-	1	V	
INH1 Pin Open Circuit Voltage ⁴		10.5	-	15	10.5	-	15	V	
INH2 Pin Open Circuit Voltage ⁴		4	-	12	4	-	12	V	
UVLO Turn On		14.5	-	16	14.5	-	16	V	
UVLO Turn Off ⁴		13.5	-	15.5	13.5	-	15.5	V	
OUTPUT Voltage ⁵	+V _{OUT}	$T_{CASE} = 25^{\circ}\text{C}$	4.95	5.00	5.05	11.88	12.00	12.12	V
	+V _{OUT}	$T_{CASE} = -55^{\circ}\text{C}$ to $+125^{\circ}\text{C}$	4.925	5.00	5.075	11.82	12.00	12.18	V
	-V _{OUT}	$T_{CASE} = 25^{\circ}\text{C}$	4.80	5.00	5.20	11.80	12.00	12.20	V
	-V _{OUT}	$T_{CASE} = -55^{\circ}\text{C}$ to $+125^{\circ}\text{C}$	4.75	5.00	5.25	11.52	12.00	12.48	V
Power ^{3,6}	Total		-	-	100	-	-	110	W
	$\pm V_{OUT}$	Either Output	-	-	70	-	-	77	W
Current ^{3,6}	$\pm V_{OUT}$	Either Output	-	-	14	-	-	6.4	A
Ripple Voltage	$\pm V_{OUT}$	Full Load ⁵ , 20Hz to 10MHz	-	-	80	-	-	80	mV _{p-p}
Line Regulation	+V _{OUT}	$V_{IN} = 16\text{V}$ to 40V	-	-	20	-	-	20	mV
	-V _{OUT}	$V_{IN} = 16\text{V}$ to 40V	-	-	200	-	-	200	mV
Load Regulation	+V _{OUT}	No Load to Full Load ⁵	-	-	100	-	-	120	mV
	-V _{OUT}	No Load to Full Load ⁵	-	-	200	-	-	200	mV
Cross Regulation	-V _{OUT}	V1+ Load 30% - Load 70% V2+ Load 70% - Load 30%	-	-	450	-	-	450	mV
Voltage Trim	Full Load		-20	-	10	-20	-	10	%
Share Pin Voltage ⁴			2	-	4	2	-	4	V
EFFICIENCY	Full Load ⁵		73	79	-	80	85	-	%
LOAD FAULT POWER DISSIPATION	Overload ⁴		-	-	50	-	-	50	W
	Short Circuit		-	-	50	-	-	50	W
CAPACITIVE LOAD ⁴			-	-	500	-	-	500	μF
SWITCHING FREQUENCY			425	500	600	425	500	600	kHz
SYNC FREQUENCY RANGE	$V_H - V_L = 5\text{V}$ Duty Cycle = 20% - 80%		500	-	600	500	-	600	kHz
ISOLATION	500 V _{DC} , $T_{CASE} = 25^{\circ}\text{C}$		100	-	-	100	-	-	M Ω
MTBF (MIL-HDBK-217F)	SF @ $T_C = 55^{\circ}\text{C}$		-	727	-	-	727	-	kHrs

SPECIFICATIONS ($T_{CASE} = -55^{\circ}\text{C}$ to $+125^{\circ}\text{C}$, $V_{IN} = +28\text{V} \pm 5\%$, Full Load⁵, Unless Otherwise Specified)

ABSOLUTE MAXIMUM RATINGS

Input Voltage (Continuous)	40 V _{DC}	Junction Temperature Rise to Case	+15°C
Input Voltage (Transient, 1 second)	50 Volts	Storage Temperature	-65°C to +150°C
Output Power ¹	120 Watts	Lead Solder Temperature (10 seconds)	270°C
Power Dissipation (Full Load, $T_{CASE} = +125^{\circ}\text{C}$)	40 Watts	Weight (Maximum) (No Pin Extensions)	88 Grams

Parameter	Conditions	SVFL2805D			SVFL2812D			Units	
		Min	Typ	Max	Min	Typ	Max		
DYNAMIC									
Load Step Output Transient	$\pm V_{OUT}$	Half Load to Full Load	-	-	400	-	-	500	mV _{PK}
Load Step Recovery ²			-	-	500	-	-	500	μSec
Line Step Output Transient ⁴	$\pm V_{OUT}$	$V_{IN} = 16\text{V}$ to 40V	-	300	600	-	600	1200	mV _{PK}
Line Step Recovery ^{2,4}			-	300	500	-	300	500	μSec
Turn On Delay	$\pm V_{OUT}$	$V_{IN} = 0\text{V}$ to 28V	-	-	20	-	-	20	mSec
Turn On Overshoot			-	-	25	-	-	50	mV _{PK}

- Notes:
1. Dependant on output voltage.
 2. Time for output voltage to settle within 1% of its nominal value.
 3. Derate linearly to 0 at 135°C.
 4. Verified by qualification testing.
 5. Half load at +V_{OUT} and half load at -V_{OUT}.
 6. Up to 70% of the total power or current can be drawn from any one of the two outputs.

SPECIFICATIONS ($T_{CASE} = -55^{\circ}\text{C}$ to $+125^{\circ}\text{C}$, $V_{IN} = +28\text{V} \pm 5\%$, Full Load⁵, Unless Otherwise Specified)

ABSOLUTE MAXIMUM RATINGS

Input Voltage (Continuous)	40 V _{DC}	Junction Temperature Rise to Case	+15°C
Input Voltage (Transient, 1 second)	50 Volts	Storage Temperature	-65°C to +150°C
Output Power ¹	120 Watts	Lead Solder Temperature (10 seconds)	270°C
Power Dissipation (Full Load, $T_{CASE} = +125^{\circ}\text{C}$)	40 Watts	Weight (Maximum) (No Pin Extensions)	88 Grams

Parameter	Conditions	SVFL2815D			Units	
		Min	Typ	Max		
STATIC						
INPUT Voltage ⁴	Continuous	16	28	40	V	
	Transient, 1 sec	-	-	50	V	
Current	Inhibited 1	-	-	3	mA	
	Inhibited 2	-	-	70	mA	
	No Load	-	-	160	mA	
Ripple Current	Full Load ⁵ , 20Hz to 10MHz	-	-	80	mA _{p-p}	
INH1 Pin Input ⁴		0	-	1.5	V	
INH2 Pin Input ⁴		0	-	1	V	
INH1 Pin Open Circuit Voltage ⁴		10.5	-	15	V	
INH2 Pin Open Circuit Voltage ⁴		4	-	12	V	
UVLO Turn On		14.5	-	16	V	
UVLO Turn Off ⁴		13.5	-	15.5	V	
OUTPUT Voltage ⁵	+V _{OUT}	$T_{CASE} = 25^{\circ}\text{C}$	14.85	15.00	15.15	V
	+V _{OUT}	$T_{CASE} = -55^{\circ}\text{C}$ to $+125^{\circ}\text{C}$	14.775	15.00	15.225	V
	-V _{OUT}	$T_{CASE} = 25^{\circ}\text{C}$	14.80	15.00	15.20	V
	-V _{OUT}	$T_{CASE} = -55^{\circ}\text{C}$ to $+125^{\circ}\text{C}$	14.40	15.00	15.60	V
Power ^{3,6}	Total	-	-	120	W	
	$\pm V_{OUT}$	Either Output	-	-	84	W
Current ^{3,6}	$\pm V_{OUT}$	Either Output	-	-	5.6	A
Ripple Voltage	$\pm V_{OUT}$	Full Load ⁵ , 20Hz to 10MHz	-	-	80	mV _{p-p}
Line Regulation	+V _{OUT}	$V_{IN} = 16\text{V}$ to 40V	-	-	20	mV
	-V _{OUT}	$V_{IN} = 16\text{V}$ to 40V	-	-	200	mV
Load Regulation	+V _{OUT}	No Load to Full Load ⁵	-	-	120	mV
	-V _{OUT}	No Load to Full Load ⁵	-	-	200	mV
Cross Regulation	-V _{OUT}	V1+ Load 30% - Load 70% V2+ Load 70% - Load 30%	-	-	450	mV
Voltage Trim	Full Load		-20	-	10	%
Share Pin Voltage ⁴			2	-	4	V
EFFICIENCY	Full Load ⁵		81	85	-	%
LOAD FAULT POWER DISSIPATION	Overload ⁴		-	-	50	W
	Short Circuit		-	-	50	W
CAPACITIVE LOAD ⁴			-	-	500	μF
SWITCHING FREQUENCY			425	500	600	kHz
SYNC FREQUENCY RANGE	$V_H - V_L = 5\text{V}$ Duty Cycle = 20% - 80%		500	-	600	kHz
ISOLATION	500 V _{DC} , $T_{CASE} = 25^{\circ}\text{C}$		100	-	-	M Ω
MTBF (MIL-HDBK-217F)	SF @ $T_C = 55^{\circ}\text{C}$		-	727	-	kHrs

SPECIFICATIONS ($T_{CASE} = -55^{\circ}\text{C}$ to $+125^{\circ}\text{C}$, $V_{IN} = +28\text{V} \pm 5\%$, Full Load⁵, Unless Otherwise Specified)

ABSOLUTE MAXIMUM RATINGS

Input Voltage (Continuous)	40 V _{DC}	Junction Temperature Rise to Case	+15°C
Input Voltage (Transient, 1 second)	50 Volts	Storage Temperature	-65°C to +150°C
Output Power ¹	120 Watts	Lead Solder Temperature (10 seconds)	270°C
Power Dissipation (Full Load, $T_{CASE} = +125^{\circ}\text{C}$)	40 Watts	Weight (Maximum) (No Pin Extensions)	88 Grams

Parameter	Conditions	SVFL2815D			Units	
		Min	Typ	Max		
DYNAMIC						
Load Step Output Transient	$\pm V_{OUT}$	Half Load to Full Load	-	-	500	mV _{PK}
Load Step Recovery ²			-	-	500	μSec
Line Step Output Transient ⁴	$\pm V_{OUT}$	$V_{IN} = 16\text{V}$ to 40V	-	600	1200	mV _{PK}
Line Step Recovery ^{2,4}			-	300	500	μSec
Turn On Delay	$\pm V_{OUT}$	$V_{IN} = 0\text{V}$ to 28V	-	-	20	mSec
Turn On Overshoot			-	-	50	mV _{PK}

- Notes:
1. Dependant on output voltage.
 2. Time for output voltage to settle within 1% of its nominal value.
 3. Derate linearly to 0 at 135°C.
 4. Verified by qualification testing.
 5. Half load at $+V_{OUT}$ and half load at $-V_{OUT}$.
 6. Up to 70% of the total power or current can be drawn from any one of the two outputs.

BLOCK DIAGRAM

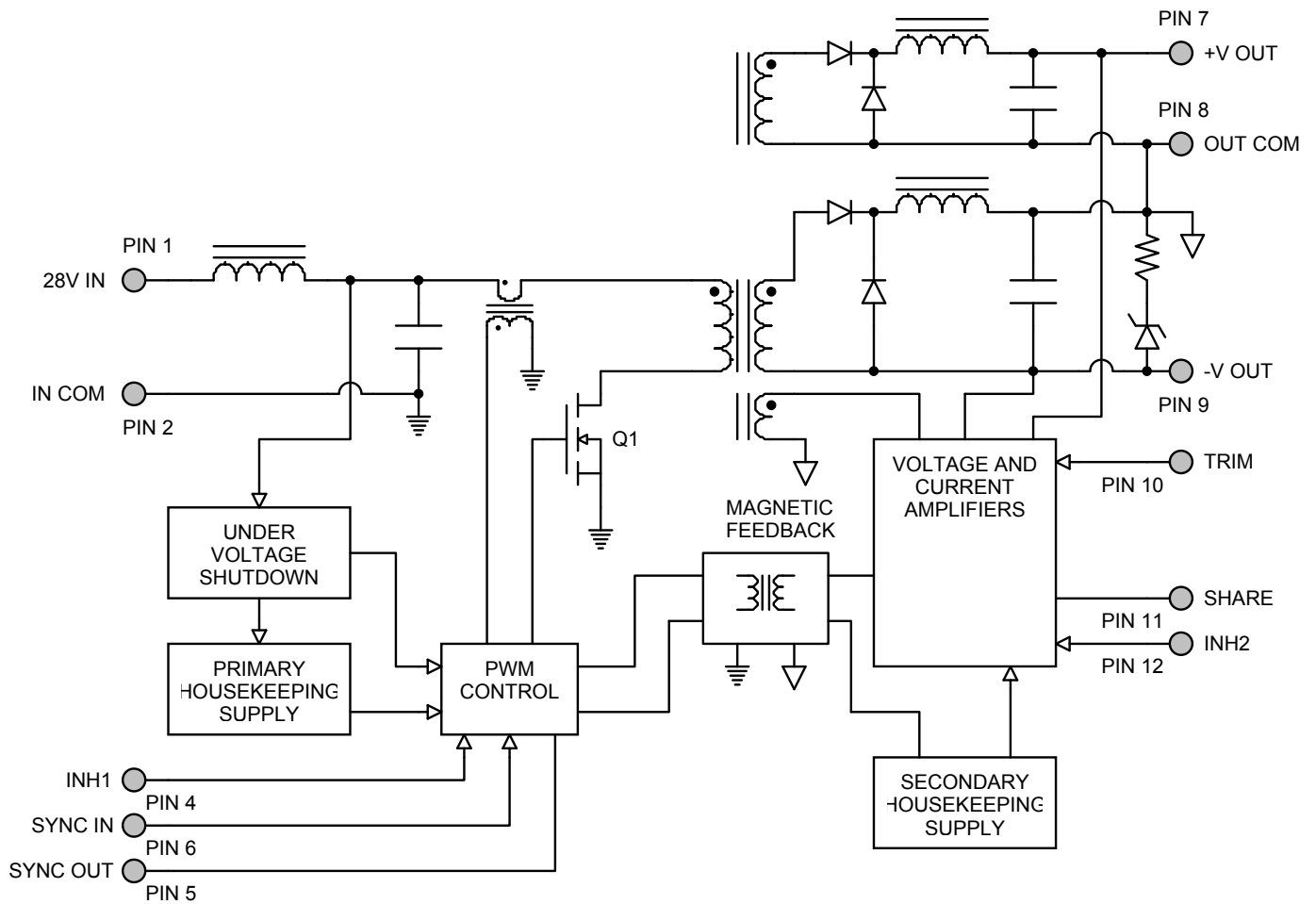

Figure 2

CONNECTION DIAGRAM

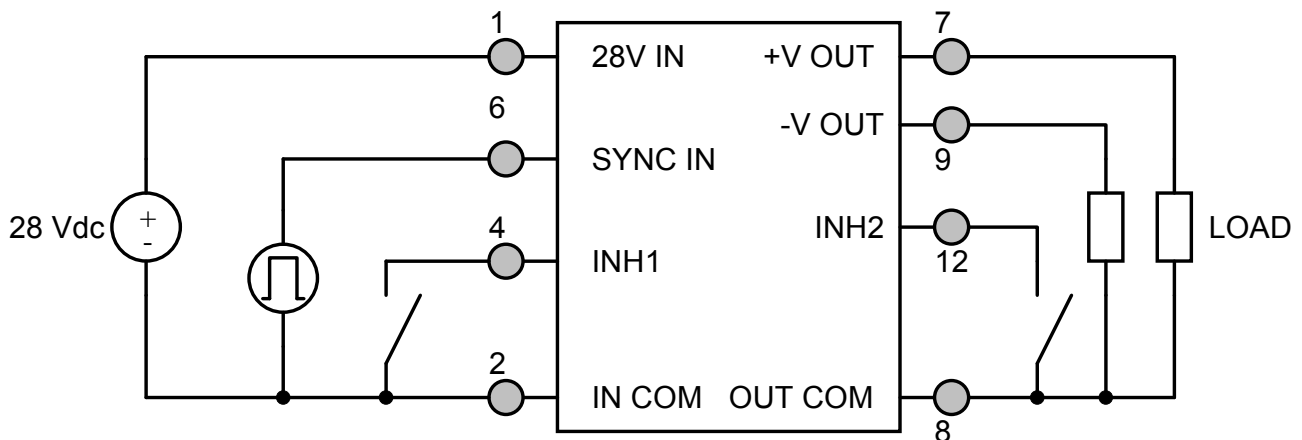

Figure 3

INHIBIT DRIVE CONNECTION DIAGRAM

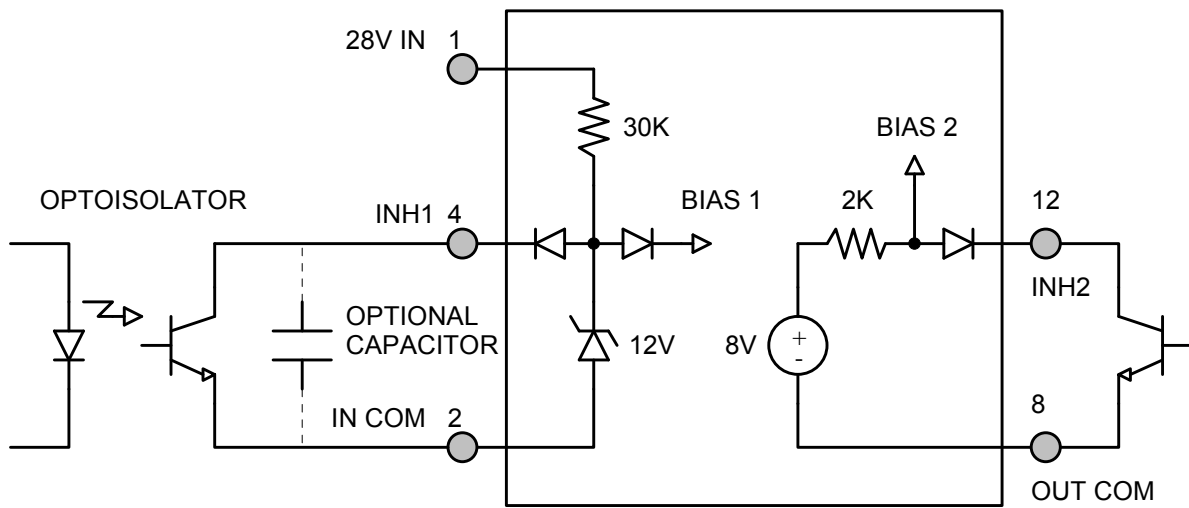

Figure 4 – Isolated Inhibit Drive and Internal Equivalent Circuit
(Shown with optional capacitor for turn-on delay)

EMI FILTER HOOKUP DIAGRAM

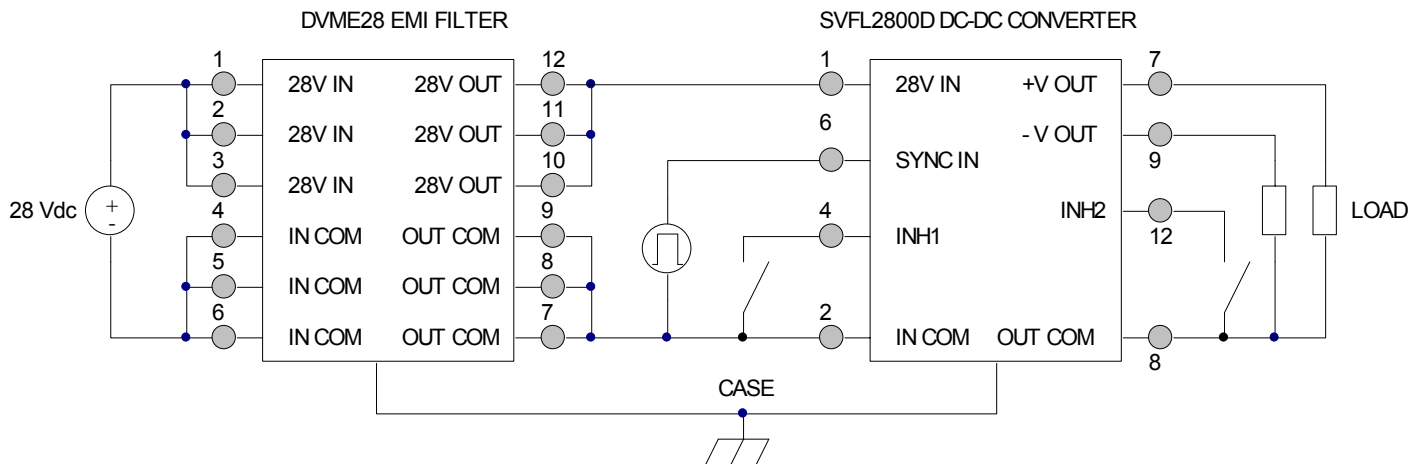

Figure 5 – Converter with EMI Filter

+28 VOLT OUTPUT CONNECTION DIAGRAM

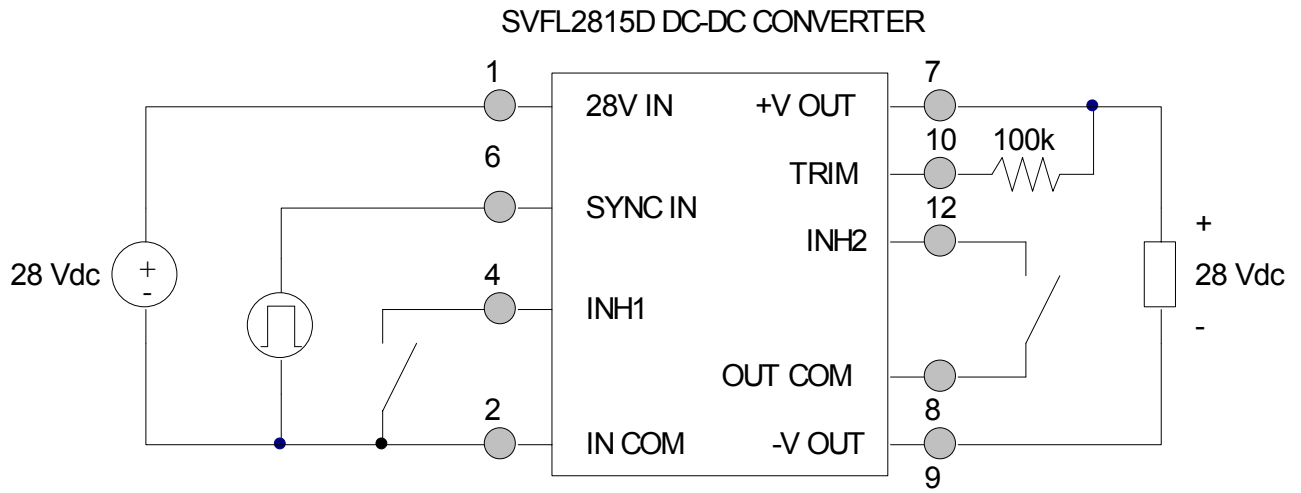

Figure 6: +28 Volt Output Converter Using SVFL2815D Converter

PARALLEL CONNECTION DIAGRAM

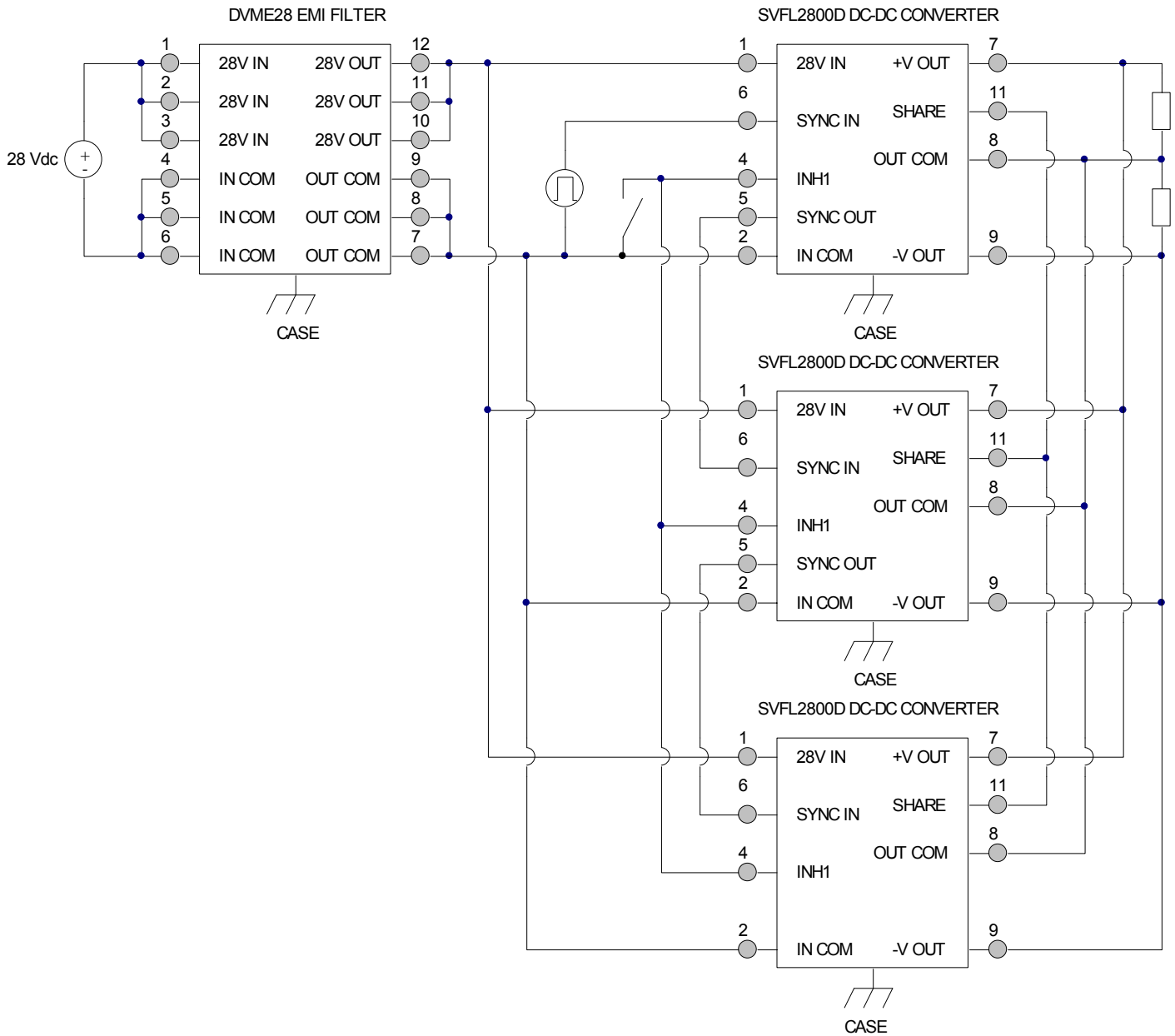
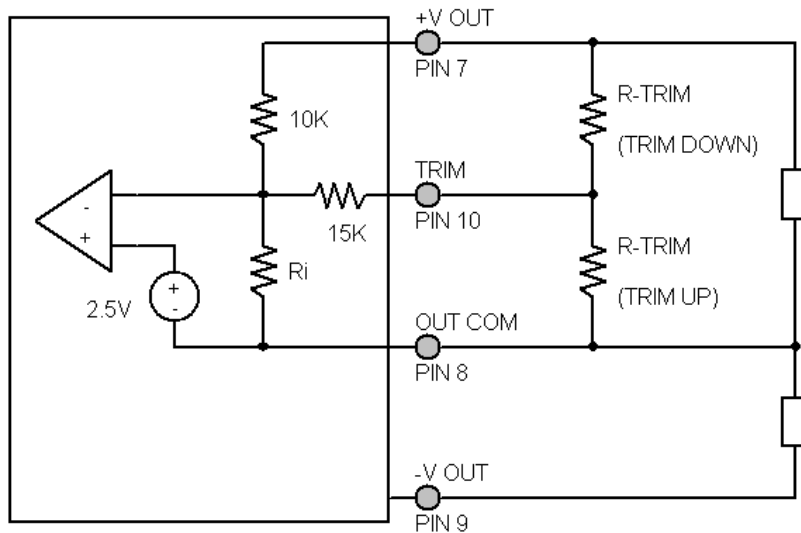

Figure 7 – Current Sharing Parallel Connection for Multiple Converters

OUTPUT VOLTAGE TRIM



The output voltage can be trimmed down by connecting a resistor between the TRIM pin (PIN 10) and the +V OUT pin (PIN 7), or can be trimmed up by connecting a resistor between the TRIM pin (PIN 10) and the OUT COM pin (PIN 8). The maximum trim range is +10% up and -20% down. The appropriate resistor values versus the output voltage are given in the trim table below.

Figure 8 – Output Voltage Trim

SVFL2805D		SVFL2812D		SVFL2815D	
$\pm V_{OUT}$ (V)	R_{TRIM} (Ω)	$\pm V_{OUT}$ (V)	R_{TRIM} (Ω)	$\pm V_{OUT}$ (V)	R_{TRIM} (Ω)
5.5	35k	13.2	5.8k	16.50	1.7k
5.4	47.5k	13.0	10k	16.25	5k
5.3	68.3k	12.8	16.2k	16.00	10k
5.2	110k	12.6	26.6k	15.75	18.3k
5.1	235k	12.4	47.3k	15.50	35k
5.0	-	12.2	109k	15.25	85k
4.9	225k	12.0	-	15.00	-
4.8	100k	11.8	454k	14.75	475k
4.7	58.3k	11.6	213k	14.50	225k
4.6	37.5k	11.4	134k	14.25	142k
4.5	25k	11.2	94k	14.00	100k
4.4	16.7k	11.0	70.1k	13.75	75k
4.3	10.7k	10.8	54.3k	13.50	58.3k
4.2	6.3k	10.6	42.9k	13.25	46.4k
4.1	2.8k	10.4	34.4k	13.00	37.5k
4.0	0	10.2	27.8k	12.75	30.6k
		10.0	22.5k	12.50	25k
		9.8	18.2k	12.25	20.5k
		9.6	14.6k	12.00	16.7k

RHA TEST CIRCUIT DIAGRAM

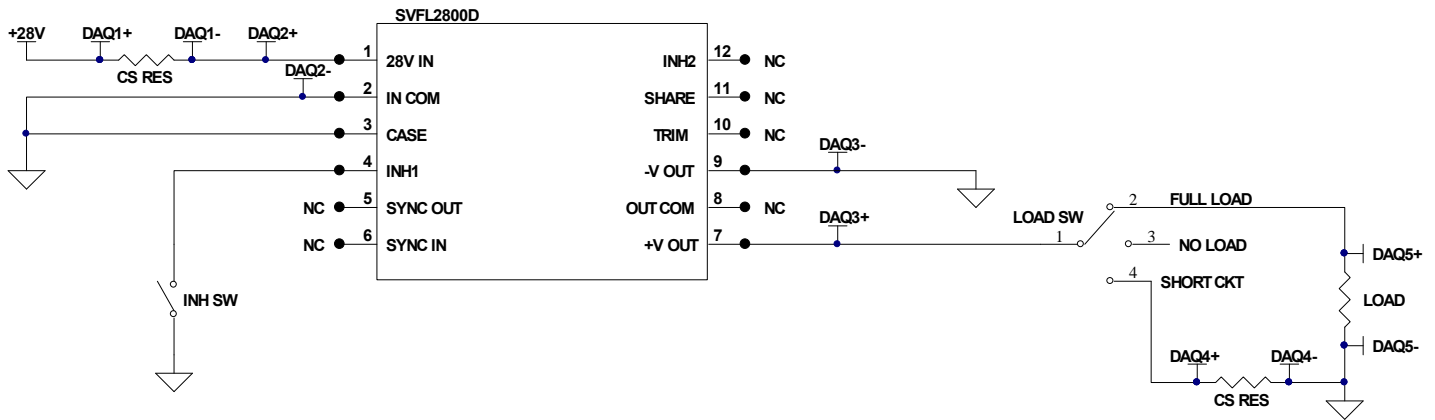

Figure 9

FREQUENCY OF RHA TESTING

Every initial wafer lot of critical semiconductor components has been characterized and tested at HDR as well as at LDR to determine if there is ELDRS sensitivity. If a specific component type is determined to have ELDRS sensitivity, all future wafer lots of that specific component will be tested at LDR. If no ELDRS sensitivity is shown in the initial wafer lot testing, future wafer lots of those specific components will not be tested at LDR. All future critical semiconductor component wafer lots are tested at HDR. If the components test to the same level (within 15% of the previous 99/90 RLAT level) or better as the wafer lot used to characterize the converter family, the converter family is not re-characterized. If the components test to a worse level, one of the following actions is performed (depending on the test level passed):

1. Component lot is not used in VPT RHA assured product.
2. Component lot is used if WCA (Worst Case Analysis) performed on the new lot against the original characterization WCA determines the component level characterized will not negatively impact the assured product characterization level.
3. The assured product is re-characterized using the new component lot.

EFFICIENCY PERFORMANCE CURVES ($T_{CASE} = 25^{\circ}C$, Full Load, Unless Otherwise Specified)

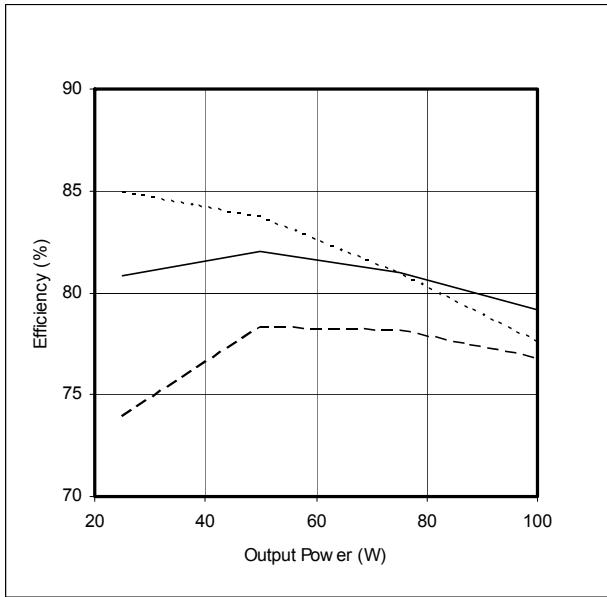

Figure 10 – SVFL2805D
Efficiency (%) vs. Output Power (W)

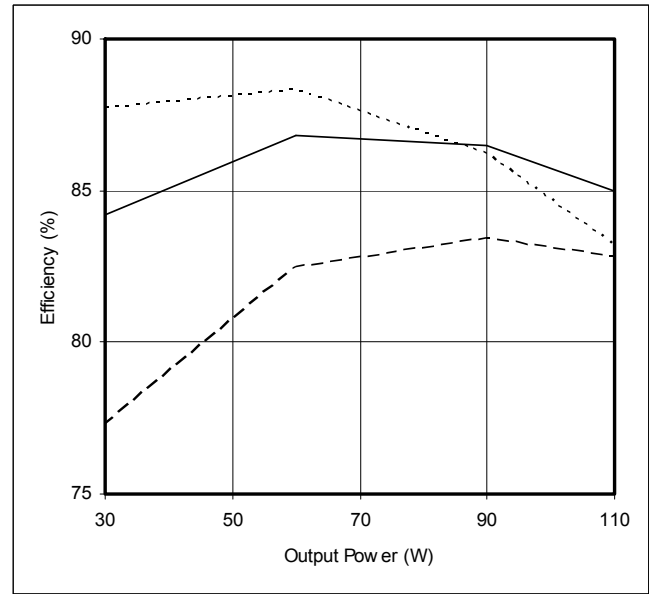

Figure 11 – SVFL2812D
Efficiency (%) vs. Output Power (W)

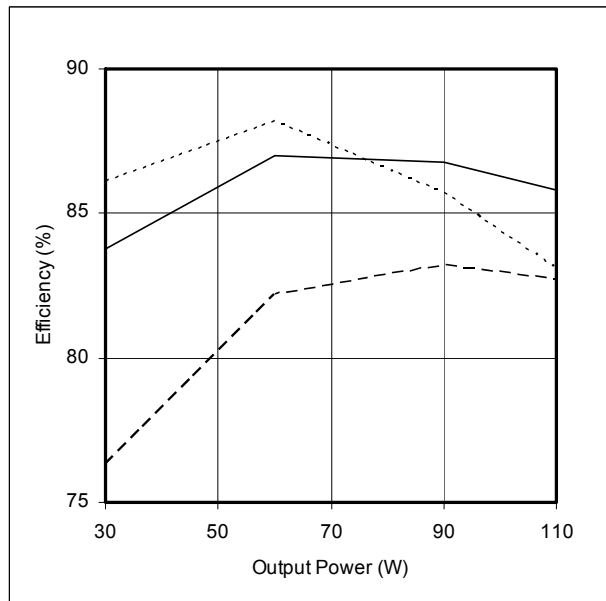

Figure 12 – SVFL2815D
Efficiency (%) vs. Output Power (W)

EMI PERFORMANCE CURVES

($T_{CASE} = 25^{\circ}C$, $V_{IN} = +28V \pm 5\%$, Full Load, Unless Otherwise Specified)

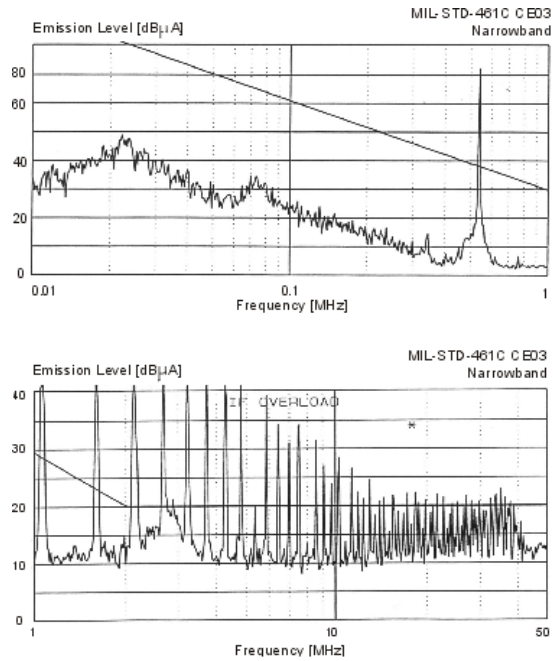

Figure 13 – SVFL2800D without EMI Filter

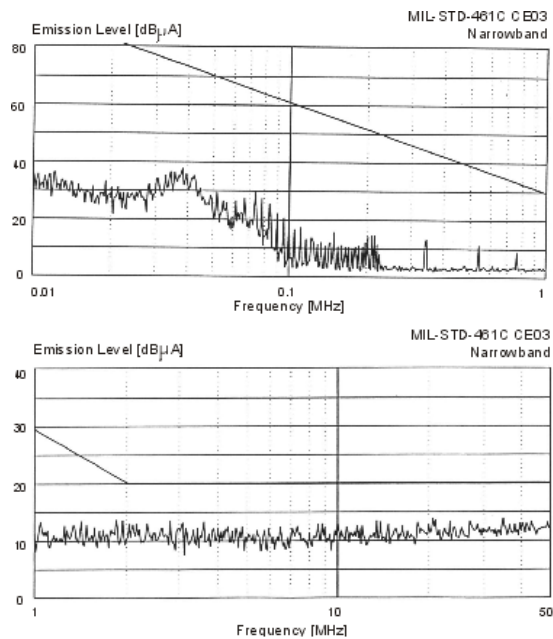
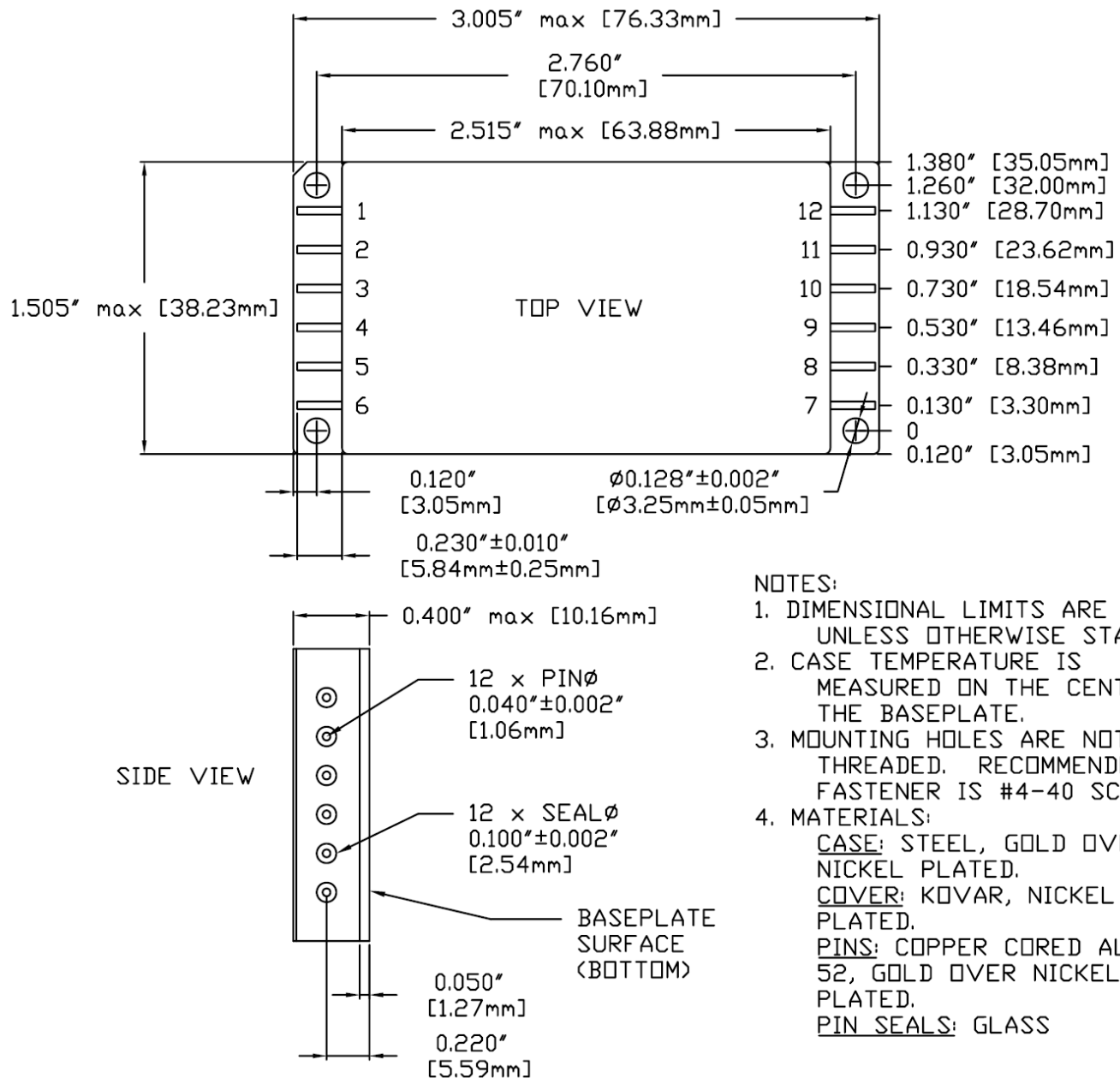

Figure 14 – SVFL2800D with EMI Filter

PACKAGE SPECIFICATIONS



- NOTES:
- DIMENSIONAL LIMITS ARE $\pm 0.005"$ UNLESS OTHERWISE STATED.
 - CASE TEMPERATURE IS MEASURED ON THE CENTER OF THE BASEPLATE.
 - MOUNTING HOLES ARE NOT THREADED. RECOMMENDED FASTENER IS #4-40 SCREW.
 - MATERIALS:
CASE: STEEL, GOLD OVER NICKEL PLATED.
COVER: KOVAR, NICKEL PLATED.
PINS: COPPER CORED ALLOY 52, GOLD OVER NICKEL PLATED.
PIN SEALS: GLASS

PIN	FUNCTION	PIN	FUNCTION	PIN	FUNCTION	PIN	FUNCTION
1	28V IN	4	INH1	7	+V OUT	10	TRIM
2	IN COM	5	SYNC OUT	8	OUT COM	11	SHARE
3	CASE	6	SYNC IN	9	-V OUT	12	INH2

Figure 15 – Package and Pinout

PACKAGE PIN DESCRIPTION

Pin	Function	Description
1	28V IN	Positive Input Voltage Connection
2	IN COM	Input Common Connection
3	CASE	Case Connection
4	INH1	Logic Low = Disabled Output. Connecting the inhibit(1) pin to input common causes converter shutdown. Logic High = Enabled Output. Unconnected or open collector TTL.
5	SYNC OUT	Output Synchronization Signal
6	SYNC IN	Input Synchronization Signal
7	+V OUT	Positive Output Voltage Connection
8	OUT COM	Output Common Connection
9	-V OUT	Negative Output Voltage Connection
10	TRIM	Trim Output Voltage to +10%, -20% of Nominal Value
11	SHARE	Current Share
12	INH2	Logic Low = Disabled Output. Connecting the inhibit(2) pin to output common causes converter shutdown. Logic High = Enabled Output. Unconnected or open collector TTL.

ENVIRONMENTAL SCREENING (100% Tested Per MIL-STD-883 as referenced to MIL-PRF-38534)

Screening	MIL-STD-883	Class H+ /H+	Engineering Model ⁵ /EM
Non-Destructive Bond Pull	Method 2023	•	•
Internal Visual	Method 2017, 2032 Internal Procedure	•	•
Temperature Cycling	Method 1010, Condition C	•	
Constant Acceleration	Method 2001, 3000g, Y1 Direction	•	
PIND	Method 2020, Condition A ²	•	
Burn-In	Method 1015, 160 hours at +125°C 24 Hours at +125°C	•	•
Final Electrical	MIL-PRF-38534, Group A ¹ 100% at 25°C	•	•
Hermeticity	Method 1014, Fine Leak, Condition A Method 1014, Gross Leak, Condition C Dip (1×10^{-3})	• •	•
External Visual	Method 2009	•	•

- Notes:
- 100% R&R testing at -55°C, +25°C, and +125°C with all test data included in product shipment.
 - PIND test Certificate of Compliance included in product shipment. This is an additional screening test not required per MIL-PRF-38534, Class H.
 - Non-Destructive bond pull per Method 2023 performed. This is an additional screening test not required per MIL-PRF-38534, Class H.
 - Please contact your sales representative or the VPT Inc. Sales Department for more information concerning additional environmental screening and testing options desired.
 - Engineering models utilize only the standard screening specified and are not considered compliant for flight use.

ORDERING INFORMATION

SVFL	28	05	D	/H+	-	XXX
1	2	3	4	5		6

(1) Product Series	(2) Nominal Input Voltage		(3) Output Voltage		(4) Number of Outputs	
SVFL	28	28 Volts	05 12 15	± 5 Volts ± 12 Volts ± 15 Volts	D	Dual

(5) Screening Code		(6) Additional Screening Code
/H+ /EM	Class H+ Engineering Model	Contact Sales

Note: Engineering models utilize only the standard screening specified and are not considered compliant for flight use. These models are intended for low volume engineering characterization. The customer must place the following statement on each line item of their purchase order(s) for /EM units when ordering engineering models:

“(Customer Name) acknowledges that the /EM unit listed in this line item is not permitted for flight use and will be used for Engineering characterization only.”

Please contact your sales representative or the VPT Inc. Sales Department for more information concerning additional environmental screening and testing, different input voltage, output voltage, power requirement, source inspection, and/or special element evaluation for space or other higher quality applications.

SMD (STANDARD MICROCIRCUIT DRAWING) NUMBERS

Standard Microcircuit Drawing (SMD)	SVFL2800D Series Similar Part Number
*T.B.D.	SVFL2805D/H+
*T.B.D.	SVFL2812D/H+
*T.B.D.	SVFL2815D/H+

VPT's certified radiation program per MIL-PRF-38534, Appendix G is currently under review by DSCC. Please contact DSCC at 614-692-0585 for details. Standard MIL-PRF-38534 Class H SMD's are available. Please see the standard product DVFL2800D datasheet for details.

Do not use the SVFL2800D Series similar part number for SMD product acquisition. It is listed for reference only. For exact specifications for the SMD product, refer to the SMD drawing. SMD's can be downloaded from the DSCC website at <http://www.dscclia.mil/programs/smcr/>. The SMD number listed above is for MIL-PRF-38534 Class H screening + PIND Testing, standard gold plated lead finish, and "P" RHA (Radiation Hardness Assurance) level. Please reference the SMD for other screening levels, lead finishes, and radiation levels. All SMD products are marked with a "Q" on the cover as specified by the QML certification mark requirement of MIL-PRF-38534.

CONTACT INFORMATION

To request a quotation or place orders please contact your sales representative or the VPT Inc. Sales Department at:

Phone: (425) 353-3010
Fax: (425) 353-4030
E-mail: vptsales@vpt-inc.com

All information contained in this datasheet is believed to be accurate, however, no responsibility is assumed for possible errors or omissions. The products or specifications contained herein are subject to change without notice.